

# Instructions for Assembly and Use Modular Scaffolding



[www.ringer.cc](http://www.ringer.cc)



**RINGER**  
GERÜSTE + SCHALUNGEN

<b>Contents</b>	<b>page</b>
I) RINGER modular scaffolding	
- Preface	3
- Components	3 - 6
- General notes	7
- Erection instructions	8 - 10
- Dismantling instructions	10
- Proper use	11
- Loading data	11 - 13
- Tie patterns and bracing requirements	14
- Platform brackets	15
III) Supporting structure	
- Regulations	16
IV) Stairs	
- Regulations	18
- Standard	19
- Assembling	20 - 23
- X-Large	24
- Assembling	25 - 28
- Need of material	29
- Anchoring	30
V) Components	31 - 33
VI) Examples	34 - 35

**Number of admission Z-8.22-869**

**German Institute of engineering**

### **Declaration of conformity**

The RINGER Company is certified according to ISO 9001 -2008

We also produce

- Aluminium scaffoldings
- Rolling towers
- Wall formwork MASTER and SYSTEM2000 - steel and aluminium
- Formwork accessories
- Platforms
- Slab formwork and concreting tables

RINGER and his suppliers have all necessary qualifications and certifications in respect of the quality of welding

# 1. Preface

This manual is made for people who build and work with RINGER Modular scaffolding system. It helps them to erect the standard, basic scaffolding structures safely and efficiently. For non standard use or more complex structures, please consult your technical services department, or contact your supplier for further advice.

Requirements mentioned in CEN standards have been considered during the development of this erection manual. Below you find the description of components, including the usage and allowed working loads. This manual gives guidance for scaffolding with nominal width of 1.00m

This user instruction is valid only to system parts of RINGER Modular scaffolding system

## 1.1 Components

### 1.1.1 Base Jack

This base jack is used as the foundation of the total scaffolding. It takes care of uneven ground levels. Adjustments can be done using the wing nut.

Adjusting range from 0 to 60 cm.

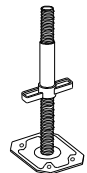

### 1.1.2 Starting tube

The starting tube creates a ground level for the scaffolding to start with

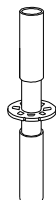

### 1.1.3 Vertical posts

Vertical posts are made from standard scaffolding tubes with wall thickness 3,2 mm and they create the vertical support of the scaffolding.

Rosettes are placed every 500 mm as a connector point for ledgers, face braces etc. They come with a centring pin for further connection.

The vertical posts have a height of 0,50 - 4,00 m.

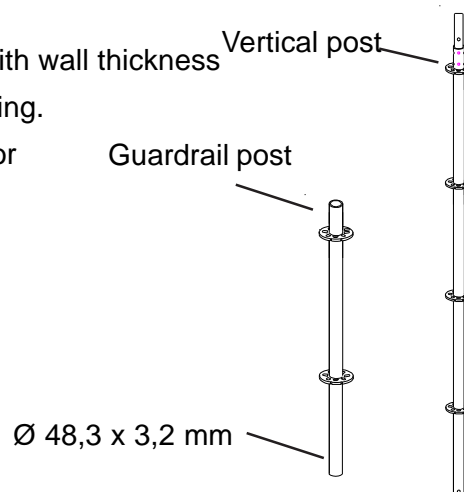

## 1.1.4 Horizontal ledgers

They are connected to the rosette of the vertical posts for the proper spacing. Can also be used as guard rails. To be fixed by hammering the wedge.

Distance from 0,73 - 3,00 m.

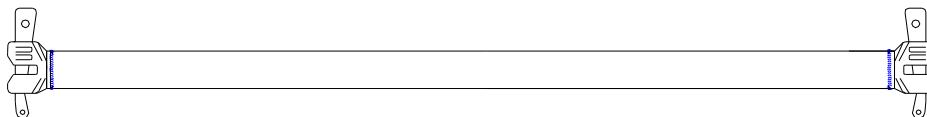

## 1.1.5 Supporting bars

Those supporting bars have to be used with heavier loads with steel platforms.

Distance from 1,50 - 2,50 m.

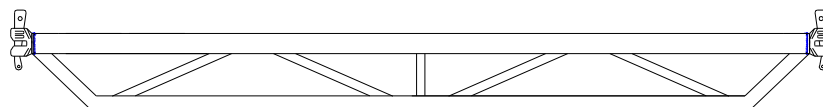

Supporting bar 0,73 m can be used with Ringer wooden platforms



## 1.1.6 Diagonal face brace

The diagonal face braces provide the stiffness of the scaffolding.

For further bracing instructions see page 14.

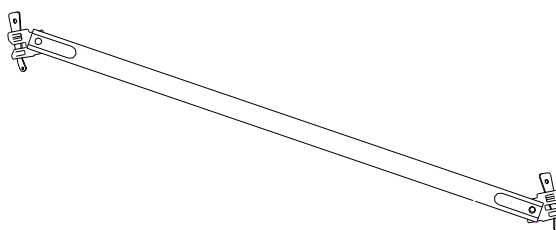

## 1.1.7 Brackets

Brackets are connected to the rosette of the vertical posts. Thus additional platform can be installed.

Available in width of 0,42 m and 0,73 m.

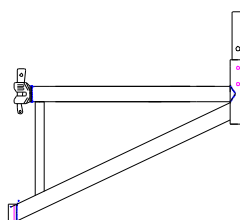

## 1.1.8 Working platforms

The Ringer-system platforms are produced according to Austrian and European standards. Minimum 10 automatically sorted strong timber boards with parallel fiber are bonded together with extra strong ship glue. Stable wood of best quality . Hot-dip galvanized edge protection. LIPOLUX-impregnated, protects from rotting and weather influences  
Length 0,72 m - 3,00 m, width: 0,30 and 0,60 m

width 0,60 m      thickness 35 mm      load capacity 200 kg/m<sup>2</sup>

width 0,30 m      thickness 45 mm      load capacity 300 kg/m<sup>2</sup>

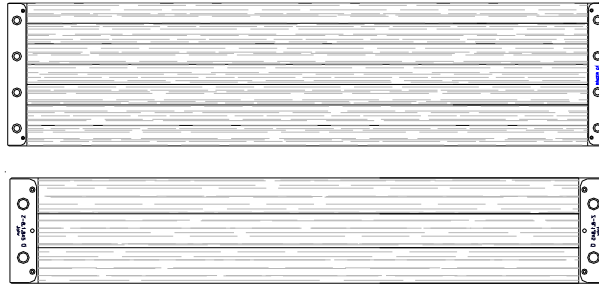

## 1.1.9 Steel platforms

Steel platforms are used as sturdy working platforms for the RINGER Modular scaffolding. They are extra safe due to slip resistant surface and intergrated protection against uplift.

Width 0,32 m and length of 0,73 - 3,00 m.

Load capacity 300 kg/m<sup>2</sup>.

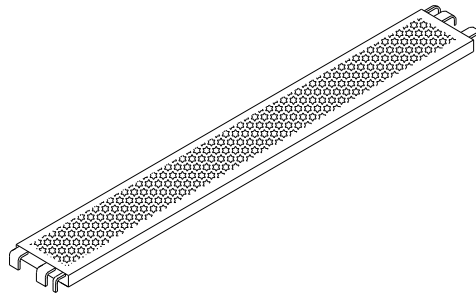

## 1.1.10 Toe board

Toe boards are used for protection against fall.

Toeboard: 15 cm high, 2 cm thick.

Length from 0,73 - 2,50 m



### 1.1.11 Anchors

Anchors are used for fixing scaffolding to the building. This insures stability and safe use of scaffolding.

Length from 0,60 - 2,70 m

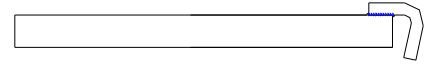

### 1.1.12 Coupler to fix toeboard and platform

These couplels are used to fix toe boards as protection against uplift.

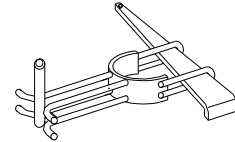

### 1.1.13 Support beam to fix platform

Support beam is fixed to horizontal ledgers.  
It is used for wooden platforms (system Ringer)  
Length from 0,63 - 1,20 m

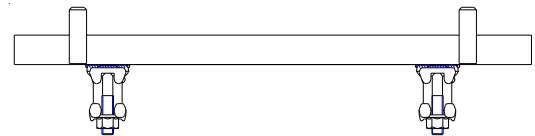

### 1.1.14 Alu stair

With stair head.  
Made of aluminium  
Length: 2,50 m  
Hight: 2,00 m  
Width: 0,60 m  
Nominal load: 1,0 kN/m<sup>2</sup>

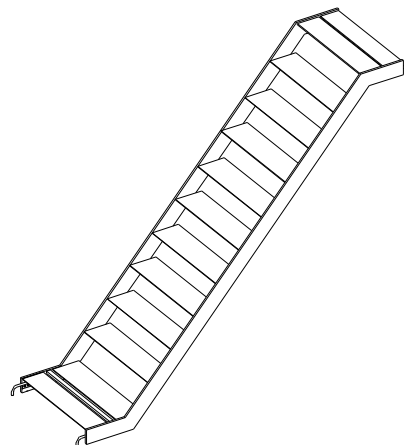

### **General notes**

The safe erection of the RINGER Modular scaffolding depends upon the following operations instructions described below and constant control. All scaffolding structures must at all times conform with the local requirements and associated standards

## **2. FOUNDATION, SHAPE AND POSITION**

### **2.1 FOUNDATION**

Base plates or adjustable base plates should be used for scaffolding foundation. The ground should be stable and firm with enough bearing capacity during the whole period of use of the scaffolding.

### **2.2 STRUCTURE AND POSITION**

1. What is the purpose of scaffolding usage?  
The answer to that question defines the structure and position of the scaffolding. For detailed information check construction site, plans and drawings
2. At all times the number and the capabilities/ experience of the scaffolders engaged in the erection of RINGER Modular scaffolding shall be such that safety and accuracy are uppermost
3. During assembly whenever possible working platforms should be used for the purpose of safety.
4. As the scaffolding erection progresses adequate bracing must be employed to ensure that scaffolding is erected straight and have enough bearing capacity.
5. Scaffolding should be anchored according to the purpose of usage and this anchoring should conform to relevant standards.
6. Platforms, toe boards and handrails should be installed in scaffolding structure
7. It is important to realize that scaffolding during erection require greater consideration in respect to local stability than a fully correctly erected scaffolding structure.

### 3. ERECTION INSTRUCTIONS

#### 3.1 STEP 1

Install starting tube on base jack

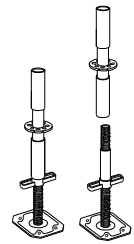

#### 3.2 STEP 2

Place base jacks according to plan and connect horizontal ledgers. Make sure that the base is exactly horizontally levelled using the base jacks as height adjustments. Take care for the distance between scaffolding and wall (take brackets in consideration)

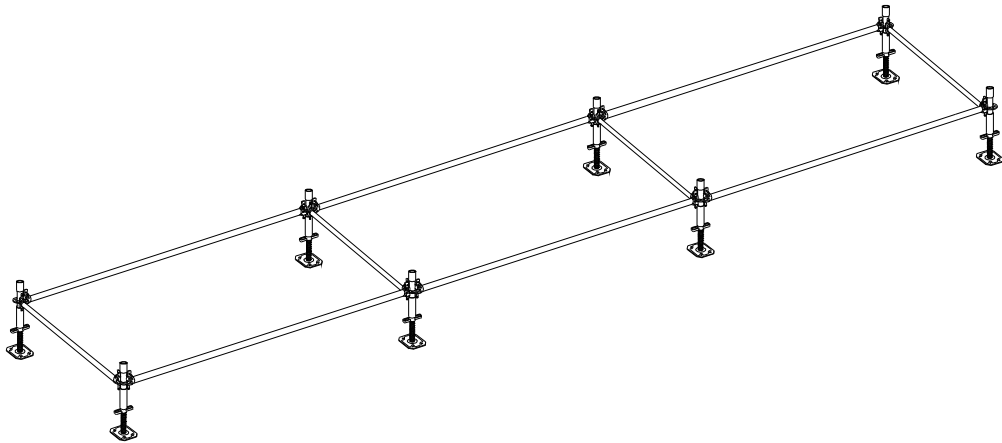

#### 3.3 STEP 3

Put vertical posts in starting tubes

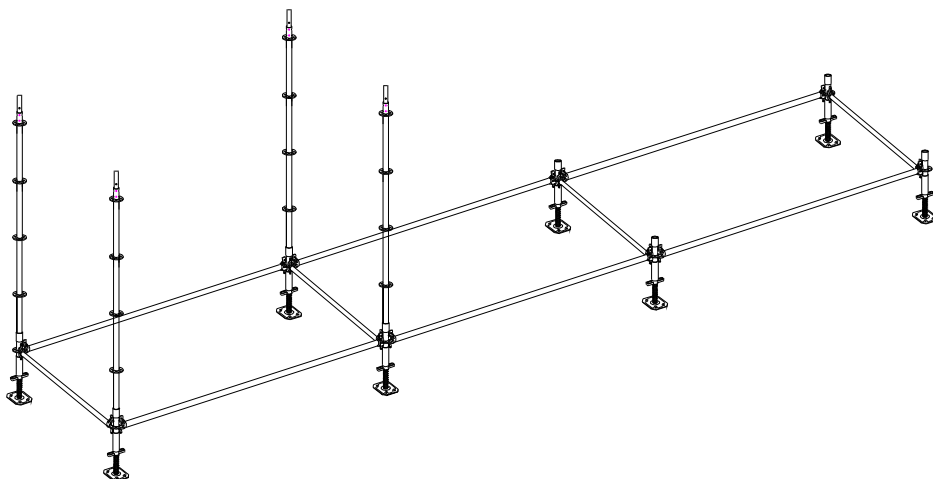

### 3.4 STEP 4

When the vertical posts are installed start assembling the second level

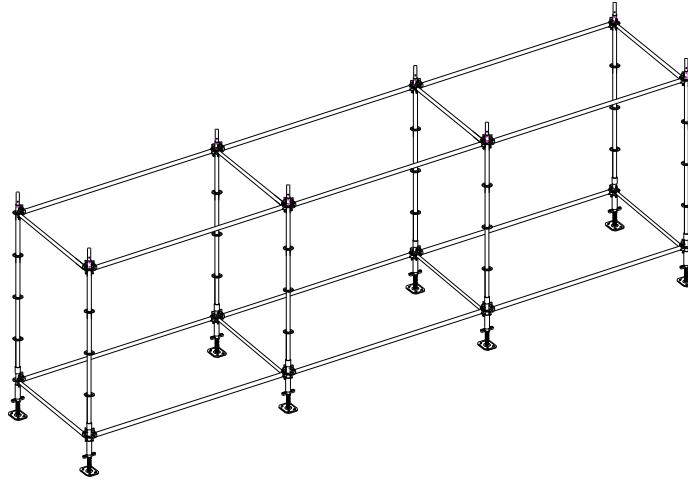

### 3.5 STEP 5

Positioning of diagonal braces.

Depending on shape, height and loading of the scaffolding, diagonal braces should be used at least every 5th scaffolding field.

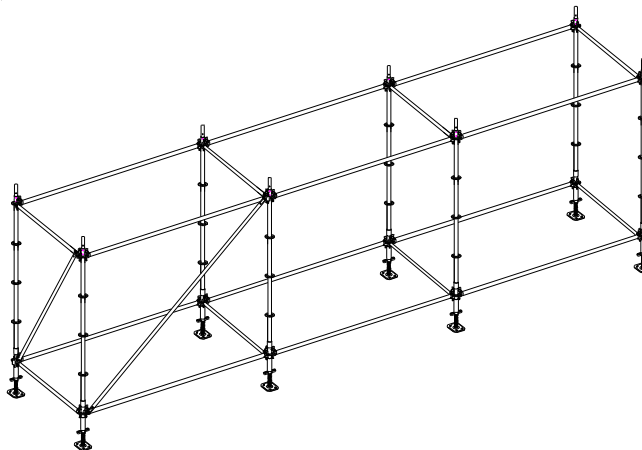

### 3.6 STEP 6

Place the wooden or steel platforms.

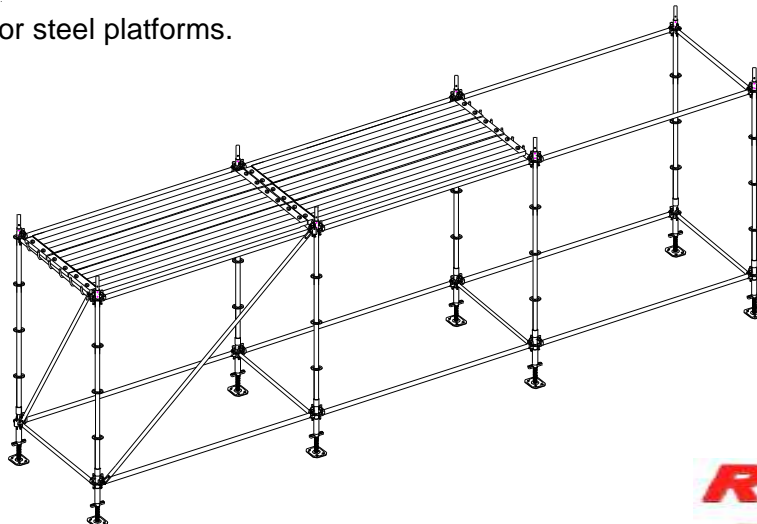

## 3.7 STEP7

Assembly the next levels and anchor accordingly

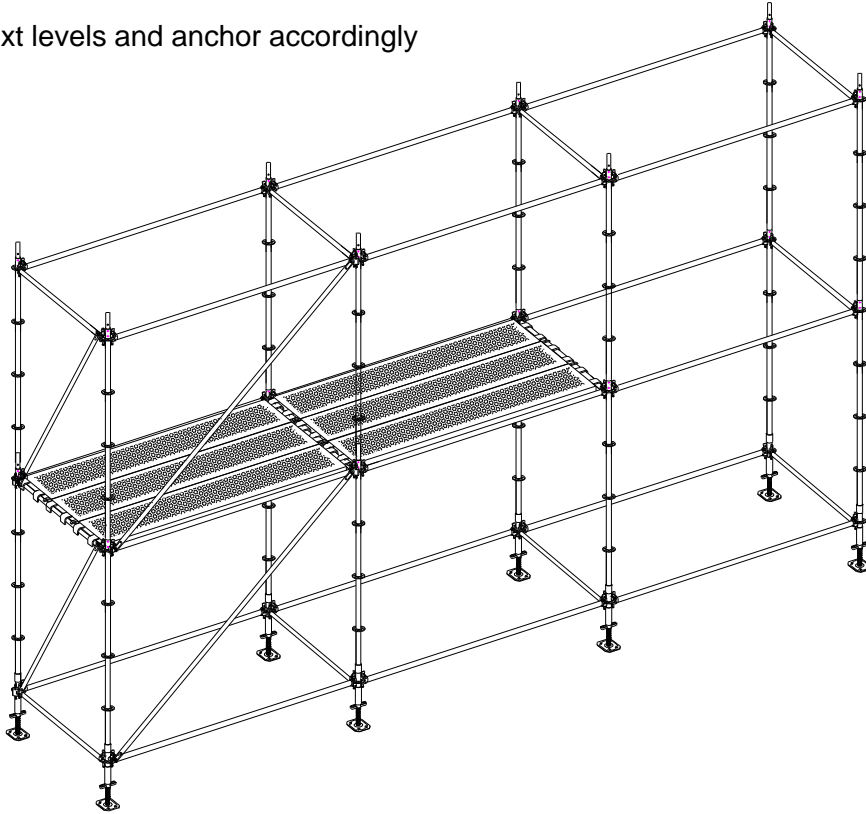

## 4. DISASSEMBLY INSTRUCTIONS

The safe dismantling of the RINGER Modular scaffolding system relies upon the following basic steps and control

1. All platforms shall be cleared of loose materials. Scaffolding anchoring should remain complete
2. Remove braces, guardrails and toe boards on the top scaffolding level.
3. Remove vertical posts. Take care that that all components previously fixed to them had been removed.
4. Remove platforms from the level below
5. Remove all ledgers and transoms from the top level.
6. Work allways from a temporary platform not more than 2m below the level from which components are to be removed, progressively dismantle the scaffolding in the sequence described above. Always disassembly only one scaffolding level
7. Remove anchors progressively as the scaffolding is disassembled. Anchors should not be removed until they would prevent further dismantling of the scaffolding.
8. Diassembled parts should be transported to the ground either by hand or with appropriate equipment such as crane or similar
9. During the process of disassembly all the used parts should be controlled. Damaged or worn out parts should be sorted out.

## 5. SAFE USE AND MAINTAINANCE

1. Before using the scaffolding please make sure, that it was erected according to technical regulations and meets the requirements of the end user.
2. The end user should know the user instructions and the permitted load capacity of the scaffolding.
3. The end user should be aware that changes of the scaffolding structure or removing of components can only be done by authorized persons
4. Make a regular control that no changes were made in the structure, no other than system parts were used
5. Changes or extensions shall only be done according to this manual or under surveillance of an expert
6. Make sure, that nobody can step on unfinished scaffold sections
7. The safe access and safe leaving of all platforms shall be warranted.
8. Platforms shall not be overloaded. Make sure that all workers know the max. load capacity of the platform.

## 6. LOADING DATA

The information given in this section is for permissible load capacity of basic RINGER Modular constructions in accordance with this scaffold guide

Where variations from the basic structure are required, they must be designed by a competent engineer.

Some examples of the more commonly encountered variations are:

- \* Non compliance with the specified tie patterns
- \* An increased number of boarded platforms
- \* Pavement gantries
- \* Exposure to heavy wind loads

The maximum service load on the scaffold is given in terms of a uniformly distributed load on the platforms and the number of loaded platforms. These figures are based on CEN HD 1000 i.e. 5 levels decked and 2 of it loaded. (one level 100% loaded and other level 50% loaded)

The scaffold has been designed to resist wind loads as specified in CEN HD - 1000

All loading data are for 1.0 m wide scaffolds not exceeding 24m in height. For scaffolds of greater height advice from a competent engineer should be sought.

The following tables give details of the allowable numbers of boarded lifts and working levels for various RINGER Modul access scaffold platform configuration

## 6.1 Permitted load without brackets

Max. permitted load	Height	Standard distance	Anchoring	Facade
Class 4 (300 kg/m <sup>2</sup> )	24 m	2,0 m	4 m	-
Class 4 (300 kg/m <sup>2</sup> )	20 m	2,0 m	8 m	-
Class 4 (300 kg/m <sup>2</sup> )	20 m	2,0 m	4 m	Yes (*)
Class 4 (300 kg/m <sup>2</sup> )	20 m	2,5 m	4 m	-
Class 4 (300 kg/m <sup>2</sup> )	16 m	2,5 m	8 m	-

(\*) supporting horizontal bracing is required

## 6.2 Permitted load with bracket 0,30 m

Max. permitted load	Height	Standard distance	Anchoring	Facade
Class 4 (300 kg/m <sup>2</sup> )	24 m	2,0 m	4 m	-
Class 4 (300 kg/m <sup>2</sup> )	20 m	2,0 m	8 m	-
Class 4 (300 kg/m <sup>2</sup> )	20 m	2,5 m	4 m	-
Class 4 (300 kg/m <sup>2</sup> )	16 m	2,5 m	8 m	-

## 6.3 PERMITTED LOAD OF COMPONENTS

### Load scheme of ledger

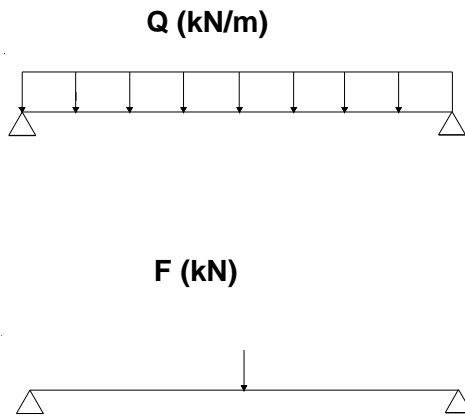

### Load scheme of diagonal

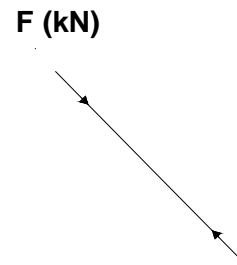

### Permitted load of tubes $\varnothing 48,3 \times 3,2$ mm:

Ledger length (m)	0,73	1,00	1,50	2,00	2,50	3,00
Uniformly distributed load (kN/m)	21,07	9,63	3,78	1,86	1,09	0,71
Point load in the center (kN)	6,76	4,66	3,35	2,50	1,83	1,43

### Permitted load of stiffened horizontal:

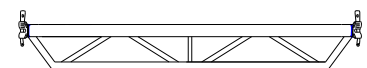

Length of horizontal (m)	1,50	2,00	2,50	3,00
Uniformly distributed load (kN/m)	11,80	8,00	4,80	3,30
Point load in the center (kN)	7,00	4,90	5,10	4,10

### Permitted load of diagonal $\varnothing 48,3 \times 3,2$ mm for tension and pressure:

Field size (m)	0,73	1,00	1,50	2,00	2,50	3,00
Diagonal $\varnothing 48,3$ mm F (kN)	+/-5,3	+/-5,6	+/-5,9	+/-5,9	+/-5,9	+/-5,9

## 7. ANCHORING PATTERNS AND BRACING REQUIREMENTS

All RINGER Modular scaffold shall be anchored to a permanent structure of sufficient strength to stabilize the scaffold. For advice on deviations from the following anchoring patterns consult your competent engineer. Anchoring patterns for wind loads have been determined for basic conditions and each case must be examined in accordance with DIN 4420-01

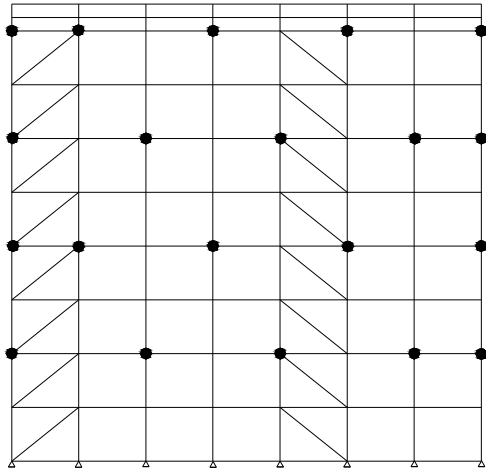

8 m anchoring pattern

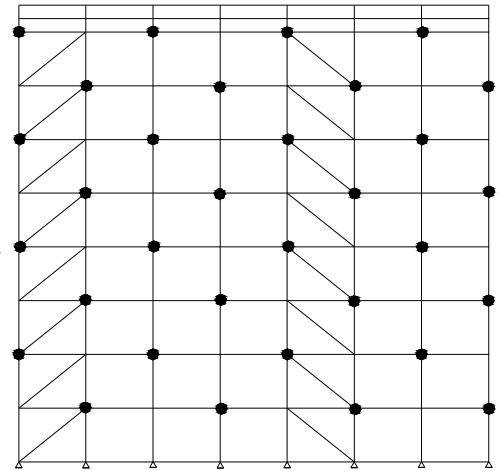

4 m anchoring pattern

Facade bracing provides extra stiffness of the scaffold. Diagonals should be placed at least every 5th bay. This can be done in different ways, as shown in the sketch

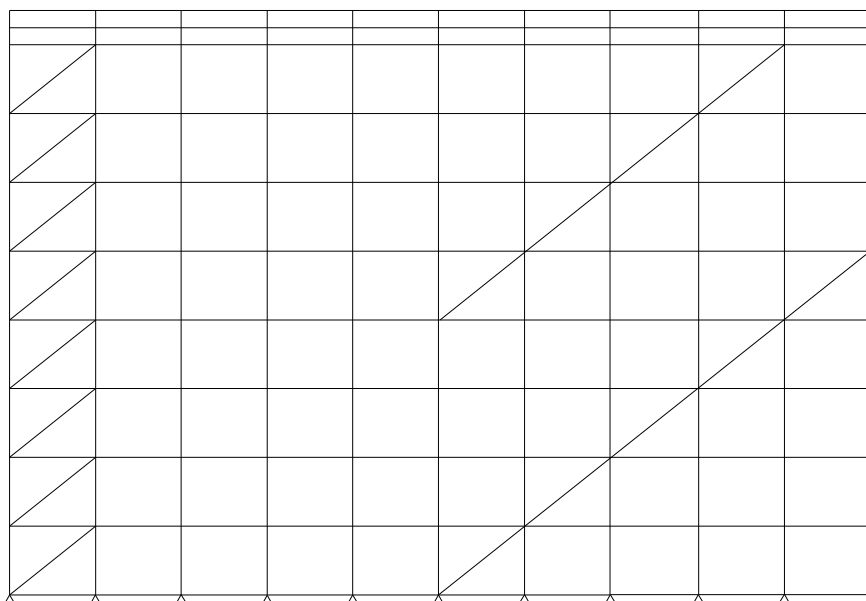

## 8. BRACKETS

There are brackets (2 widths) to build a working platform at the outside of scaffold  
Platforms and brackets should be used mainly at the main levels of the scaffold.

### 8.1 How to fix brackets

1. Connect the bracket with the rosette at the height you need
2. Repeat that at the neighbouring scaffold sections.
3. When a bracket 0,30m is used, put the platform with the matching length on it and lock the locking device
4. The platform for one scaffold section is ready now. Continue the same way for the next scaffold section
5. Whenever a 0,73 bracket is used, a connection bar with the right length has to be installed. You have to care for security
6. When the connection bar is installed, you can install the platforms and lock the locking device.
7. Repeat that procedure as often as necessary

## 9. SUPPORTING STRUCTURE

### 9.1 Determinations:

RINGER Modular scaffold is a flexible supporting scaffold to cast in place slab.

It consists of three main components

- RINGER Modular scaffold
- H20 beam
- plywood

The supporting scaffold can be used for slabs with different thickness

- As plywood we recommend a 3 - layer plywood, 27 mm thickness that is supported by H20 beams
- The same H 20 beams serve as main beams for the cross beams
- The support is done by system parts of the RINGER Modular scaffold
- Depending on required load capacity the system parts can be rearranged according to the static demands.
- The flexibility in longitudinal direction of the beams (main beam and cross beam) is affected by overlapping of beams.
- The connection of the load bearing scaffold with the main beam is affected by adjustable head spindle
- The stability of the scaffold is achieved by diagonal stiffening or anchoring



## Attention !!!!

- H20 beam  
permitted side load = 5,0 kNm  
permitted shear force = 11,0 kN

- supporting scaffold without anchors  
max. height 12 m  
base area 2,0 x 1,5 m  
slab area 3,0 x 2,65 m  
max.load 55 kN  
max.shaft load 15 kN

major heights are possible, but changes have to be made:

- anchoring
- less load
- less slab surface
- additional stiffing with diagonals

and you need a special structural analysis

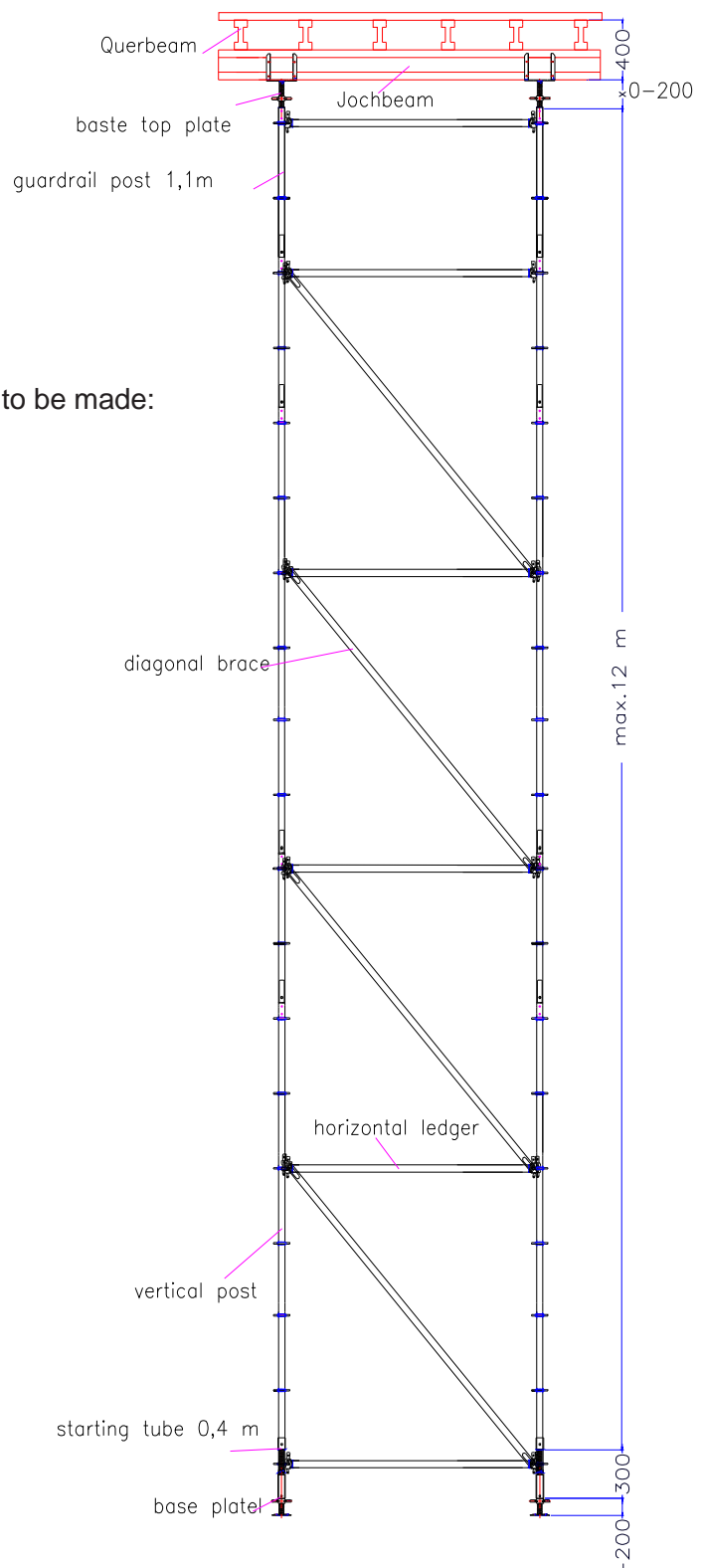

# 10. Scaffold staircase

## 10.1 GENERAL PROVISIONS

If the following rules and loads are not exceeded the scaffold staircase can be used as access to working places on scaffolds.

The staircase consists of hot dip galvanized tubes and aluminium stairs.

The base area of the staircase „Standard“ is 2,5 x 1,5 m and of X-Large: 4,0 x 1,5 m.

Special designs with different stair widths or heights and higher loads are possible.

If you move entire units with crane, vertical tubes are to be fixed with safety bolts.

## 10.2 SAFETY REGULATIONS

Anchoring loads have to be transferred into the existing building. This has to be proven in every single case

Only couplers EN 74-1 shall be used. Never exceed the permitted loads

Country specific safety regulations are to be observed

## 10.3 REFERENCE NOTE

Erect stair case parallel to the building. Distance between building and stair case should be as small as possible.

If distance < 30 cm bridge distance with an fixed device.

If distance > 30 cm you have to install a guard railing for the bridging device

The RINGER-Modular-staircase has to be erected on stable and horizontal ground.

All wedges are to be fixed with a blow of a hammer

Tools required:

- Hammer
- Open ended wrench or ring spanner



## 10.4 STAIR CASE STANDARD

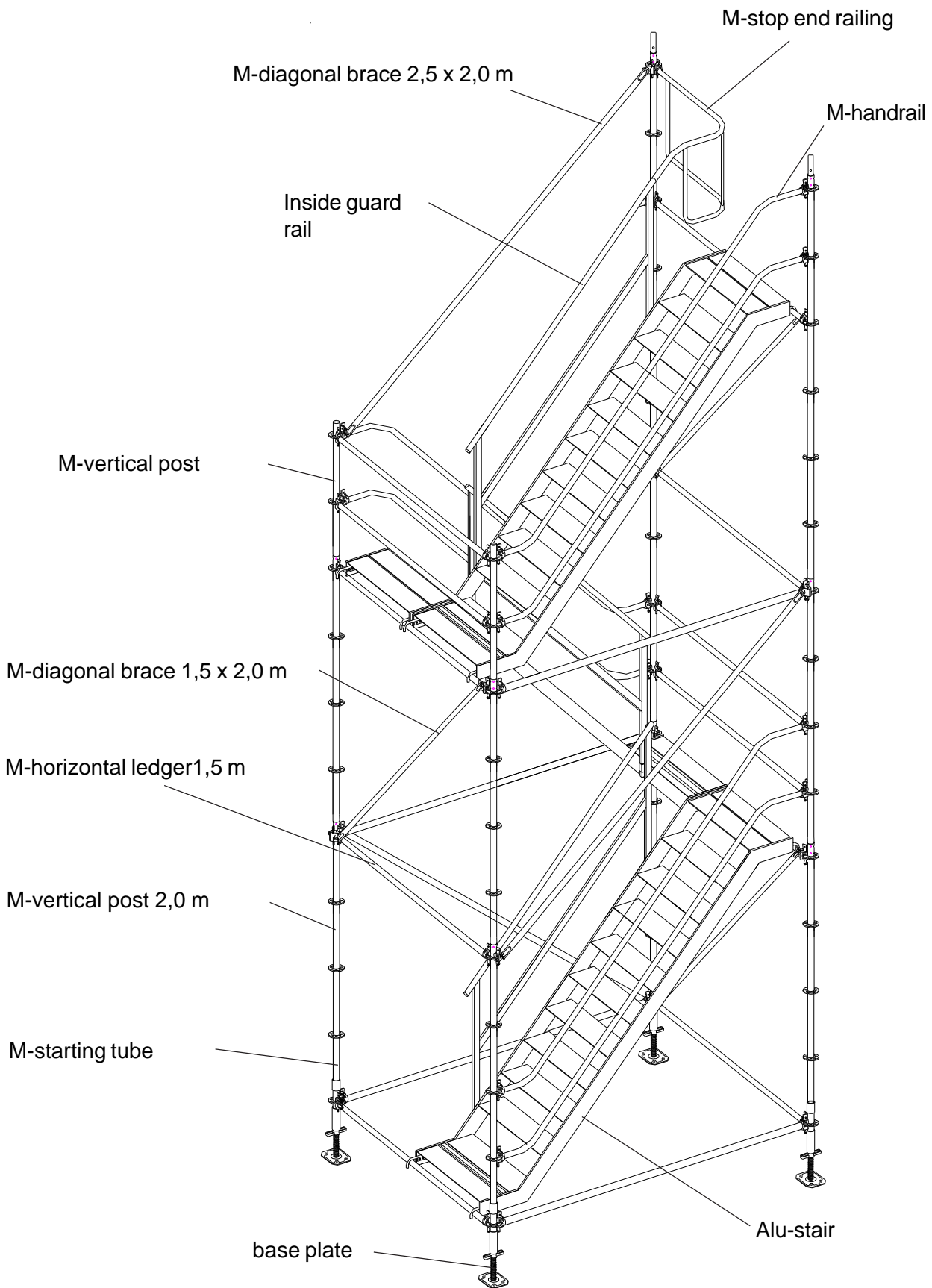

## 10.4.1 Assembling

- 10.4.1.1 Install base with 4 base plates, 4 M-starting tubes, 2 M-horizontal- ledgers 2,5 m und 2 M-horizontal - ledgers 1,5 m.  
Level with base plates and align.

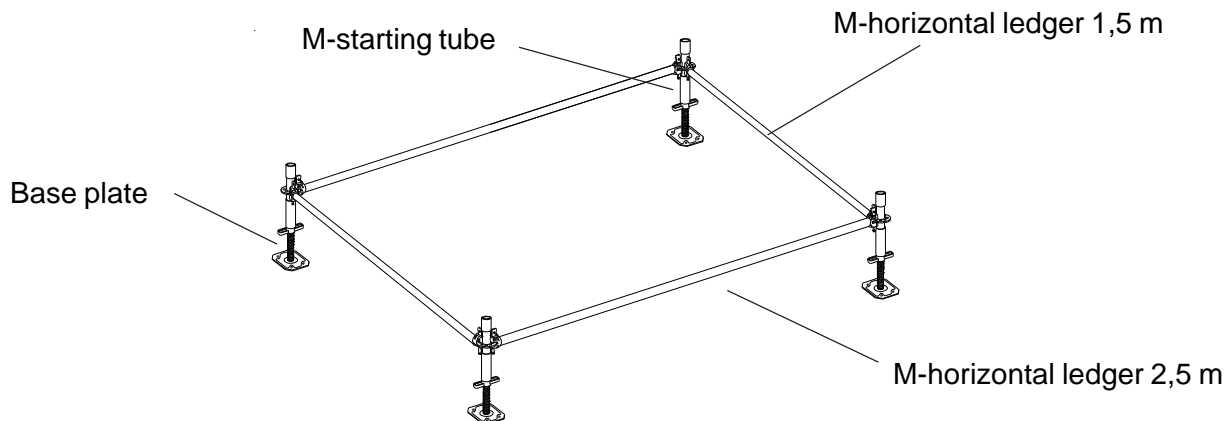

- 10.4.1.2 Assemble 4 M-vertical post 2,0 m or 3,0 m. Connect with 1 M-horizontal ledgers 2,5 m, 2 M-horizontal ledgers 1,5 m, 1 M-diagonal brace 2,5 x 2,0 m and 1 M-diagonal brace 1,5 x 2,0 m.

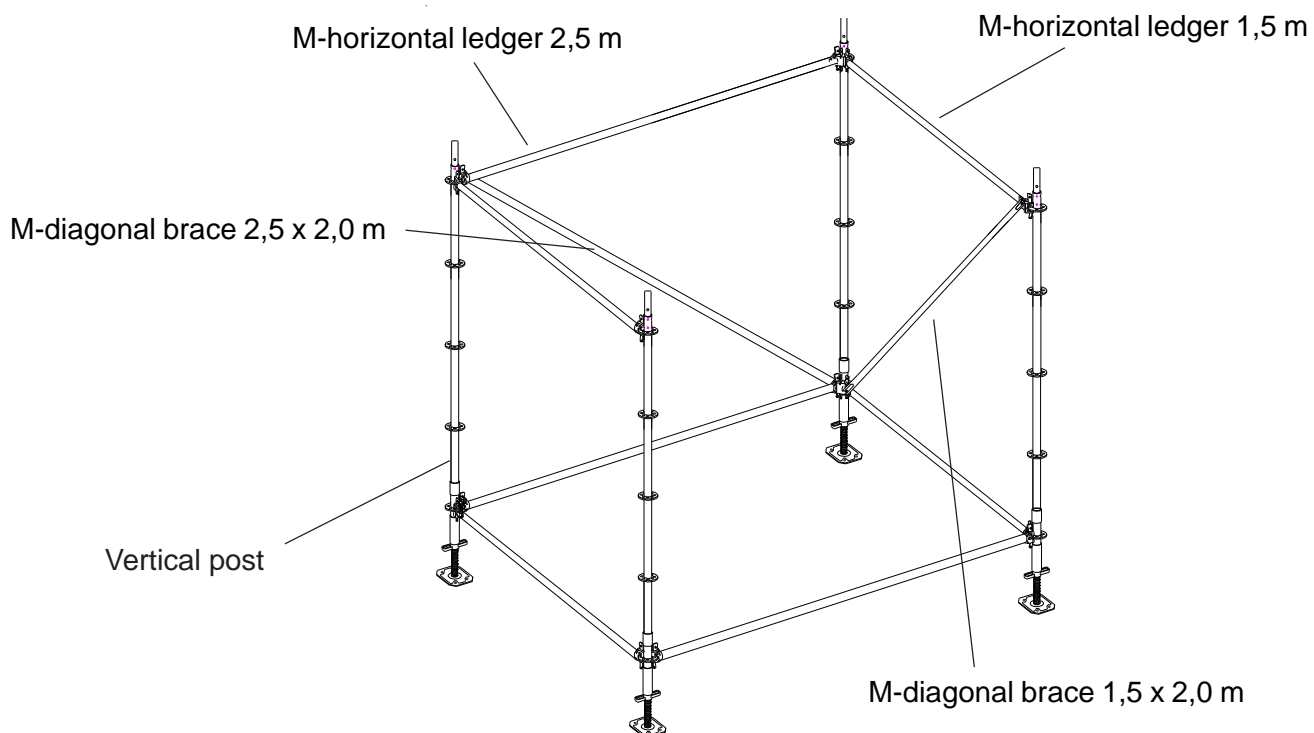

10.4.1.3 Fix Alu-stair and install inside guardrail

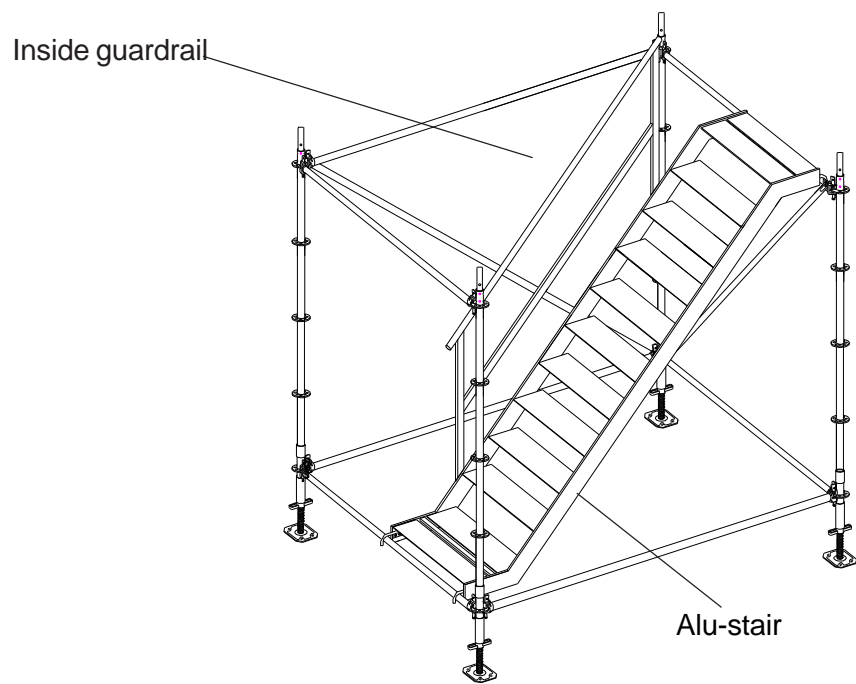

10.4.1.4 Fix 4 M-vertical posts 2,0 m (3,0 m),  
mount 2 M-handrails

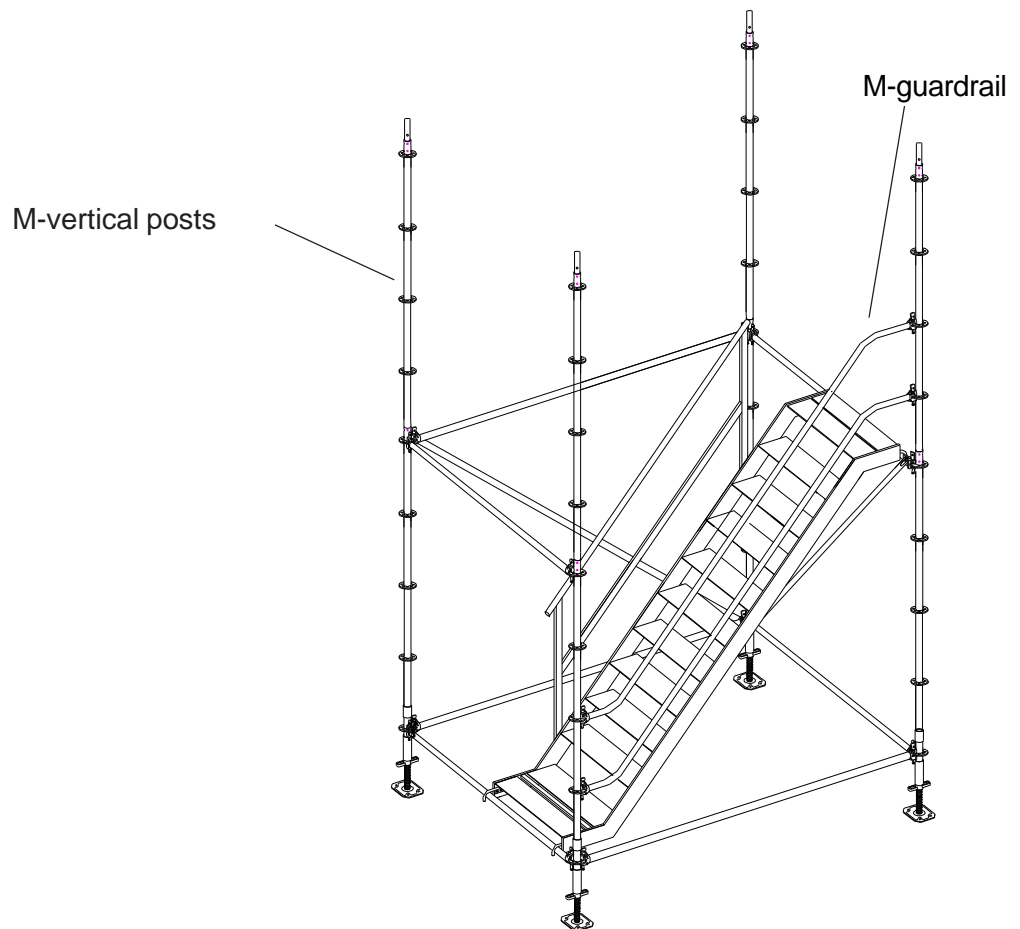

10.4.1.5 Connect with 3 M-horizontal ledger and 2 M-diagonal braces. Install side protection with 2 M-horizontal ledgers 1,5 m

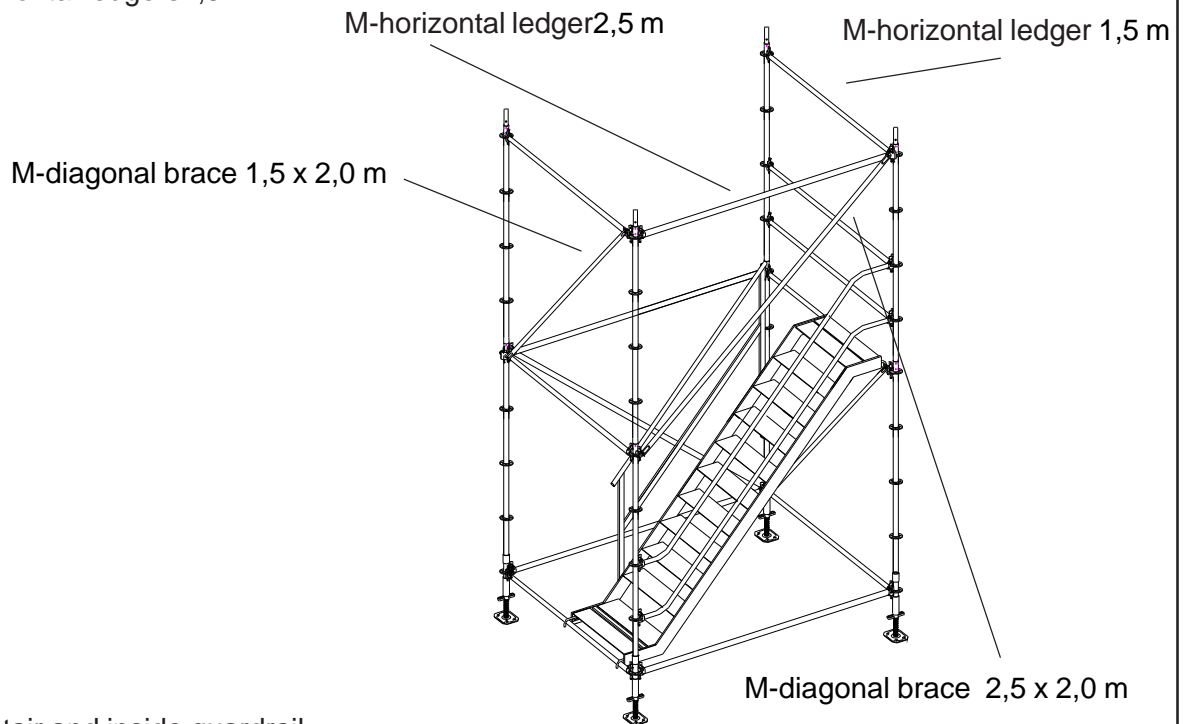

10.4.1.6 Fix Alu-stair and inside guardrail

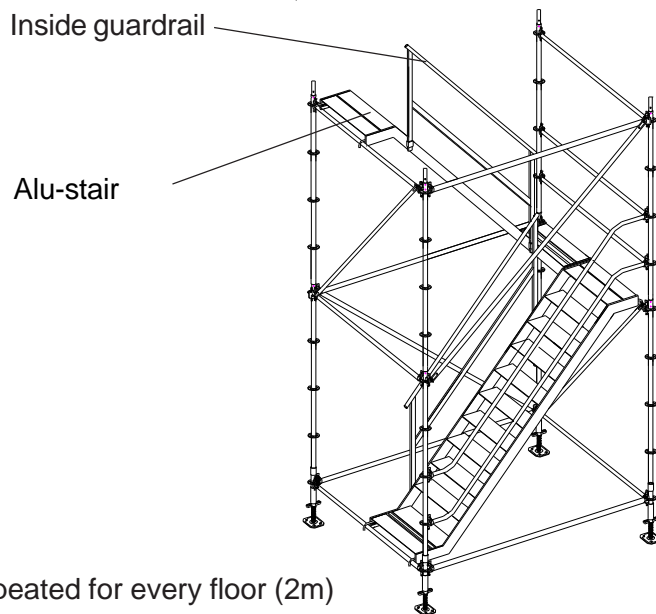

10.4.1.7 Steps 4 - 6 have to be repeated for every floor (2m)

*need of material for every floor*

- 4 M-vertical posts 2,0 m
- 2 M-horizontal ledger 1,5 m
- 1 M-horizontal ledger 2,5 m
- 1 M-diagonal brace 2,5 x 2,0 m
- 1 M-diagonal brace 1,5 x 2,0 m
- 1 Alu stair
- 1 inside guardrail
- 2 M - handrail

#### 10.4.1.8 Fix 2 handrails

Attach 2 M-vertical posts 2,0 m and 2 M-vertical posts

Attach 3 M-horizontal ledgers 1,5 m and 2 M-diagonal braces

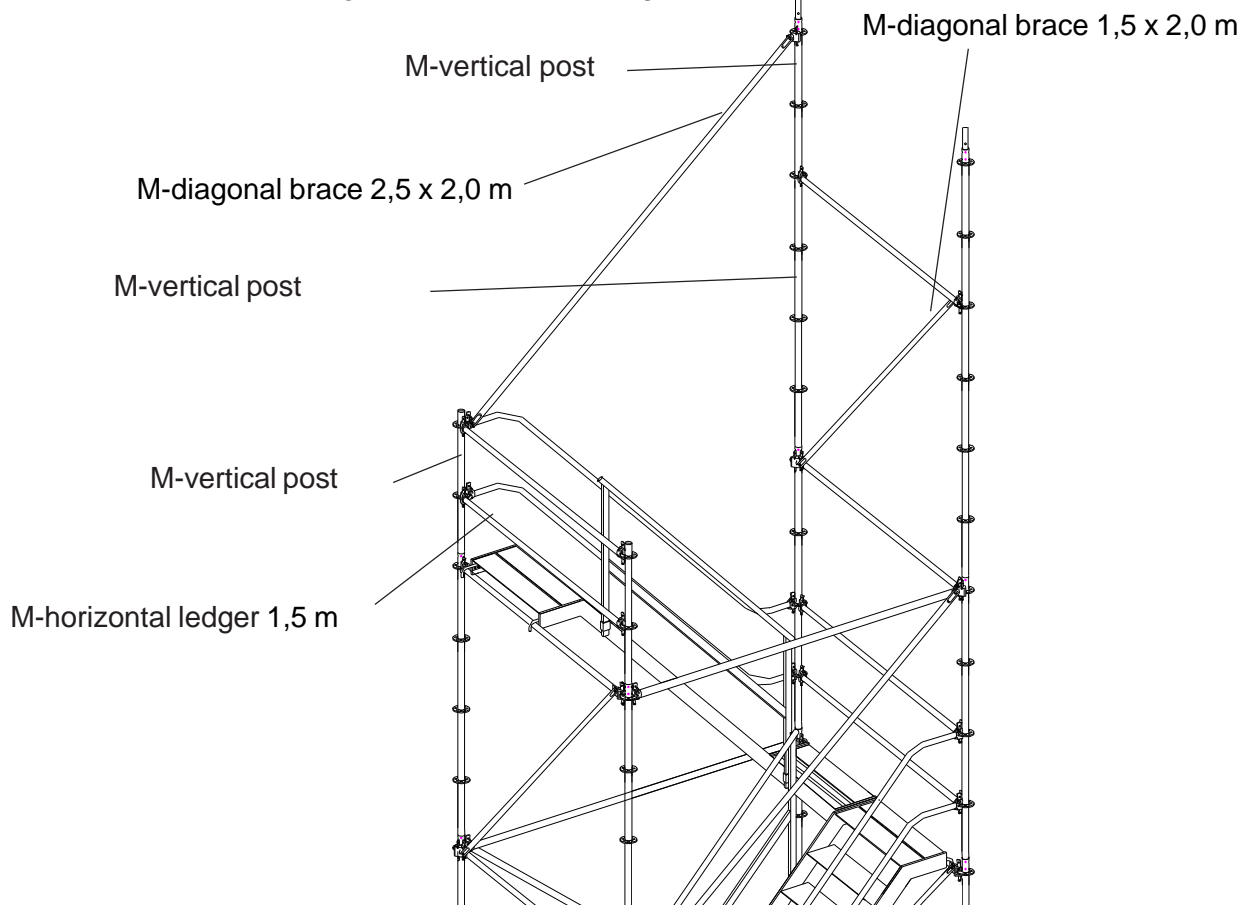

#### 10.4.1.9 Fix Alu-stair and install inside guardrail

install M-end guardrail und M-handrail

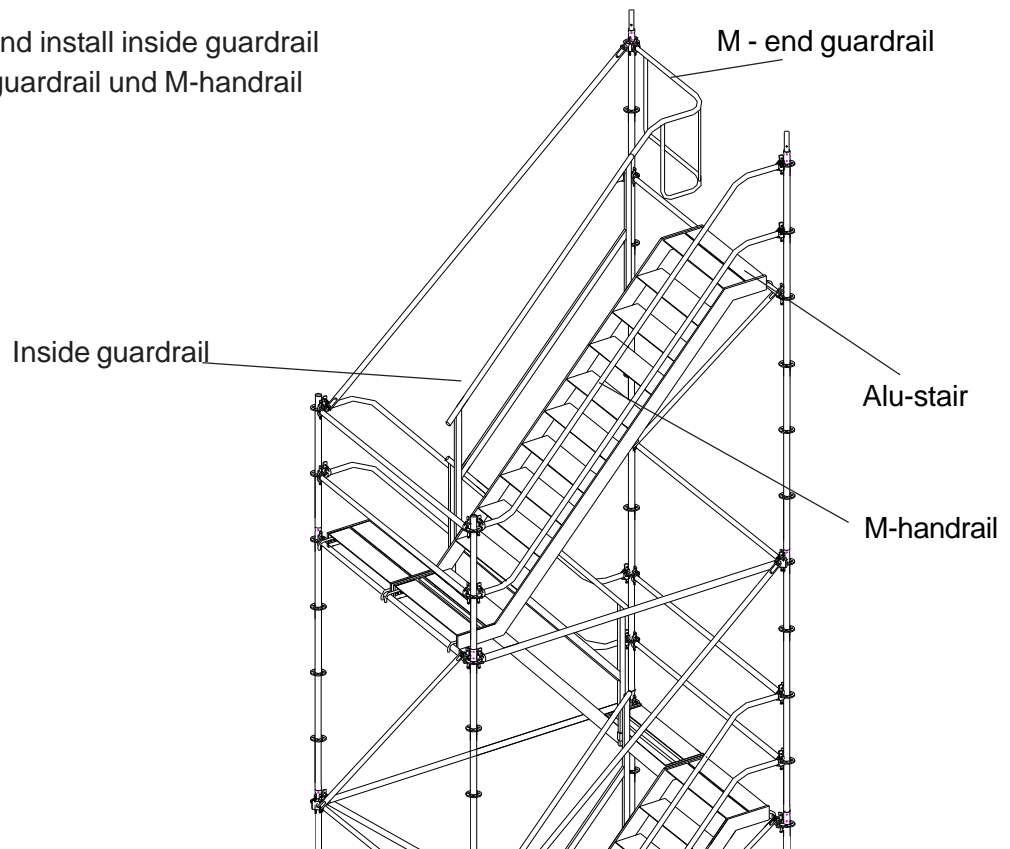

## 10.5 STAIR CASE X-LARGE

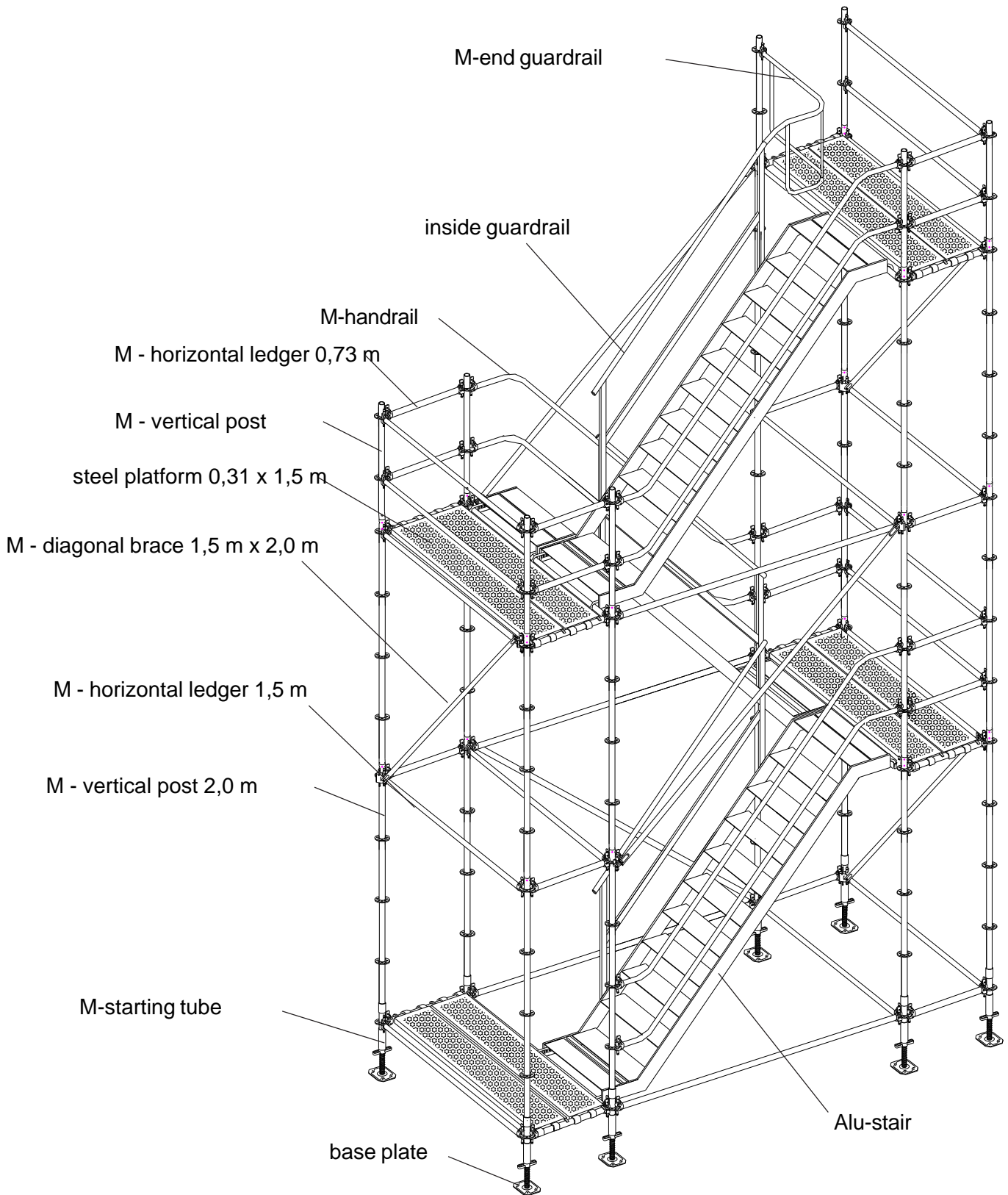

## 10.5.1 Assembling

Staircase X-Large has additional platforms at each floor.

- 10.5.1.1 Install base floor with 8 base plates, 8 M-starting tubes, 2 M-horizontal ledgers 2,5 m, 4 M-horizontal ledgers 1,5 m and 4 M-horizontal ledgers 0,73 m.  
Level with base plates and align.

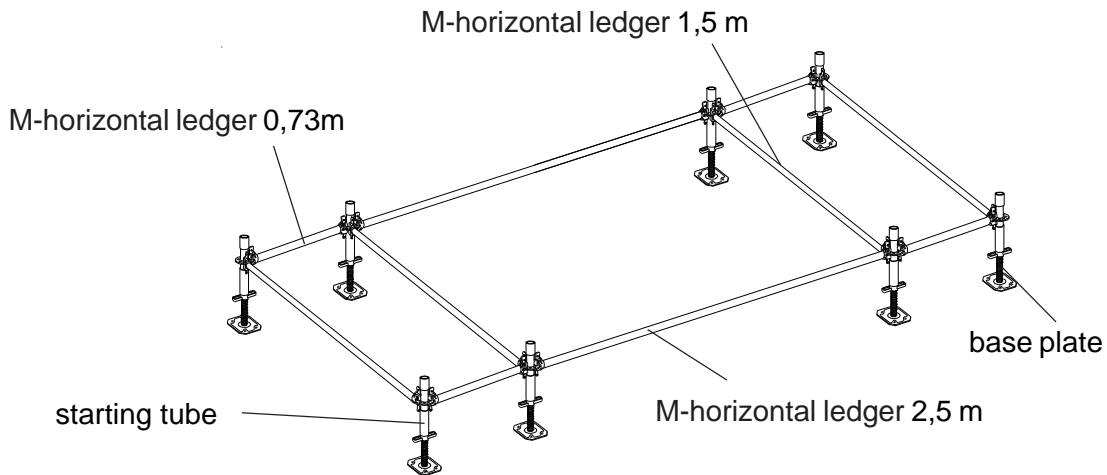

- 10.5.1.2 Fix 8 M-verical posts 2,0 m or 3,0 m . Connect with 1 M-horizontal ledger 2,5 m, 2 M-horizontal ledger 1,5 m, 4 M-horizontal ledger 0,73 m, 1 M-diagonal brace 2,5 x 2,0 m and 1 M-diagonal brace 1,5 x 2,0 m.

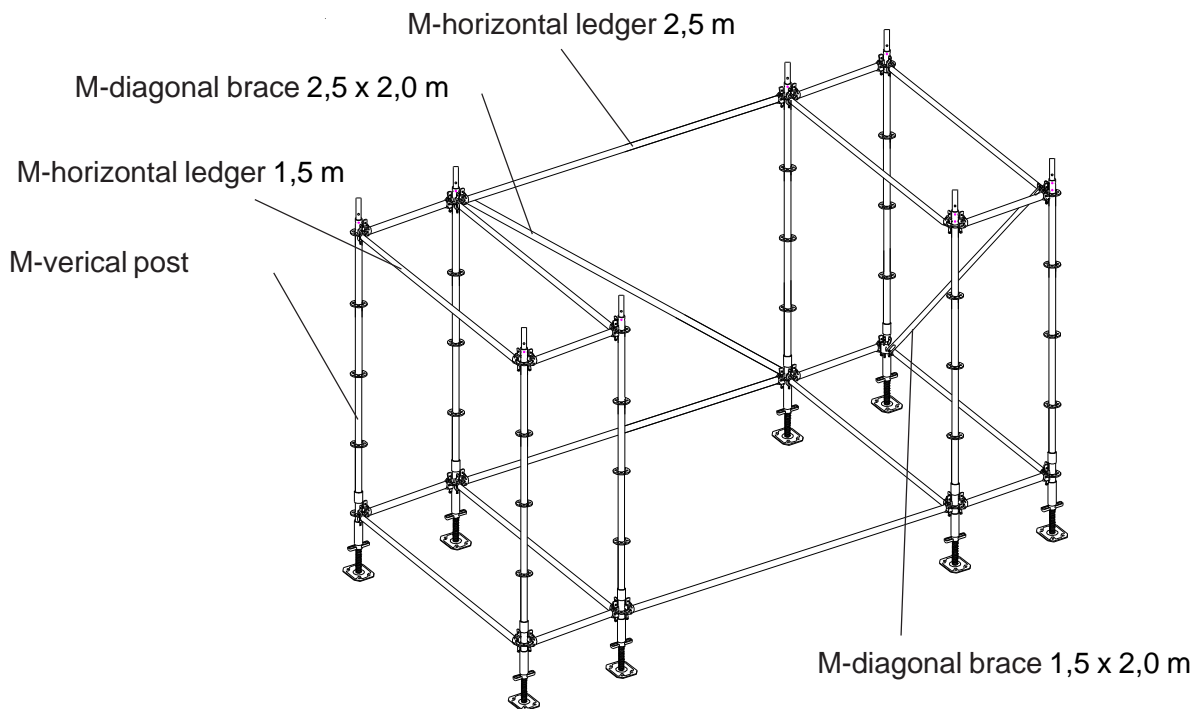

10.5.1.3 Fix Alu-stair, inside guardrail and 4 steel platforms 0,31 x 1,5 m .

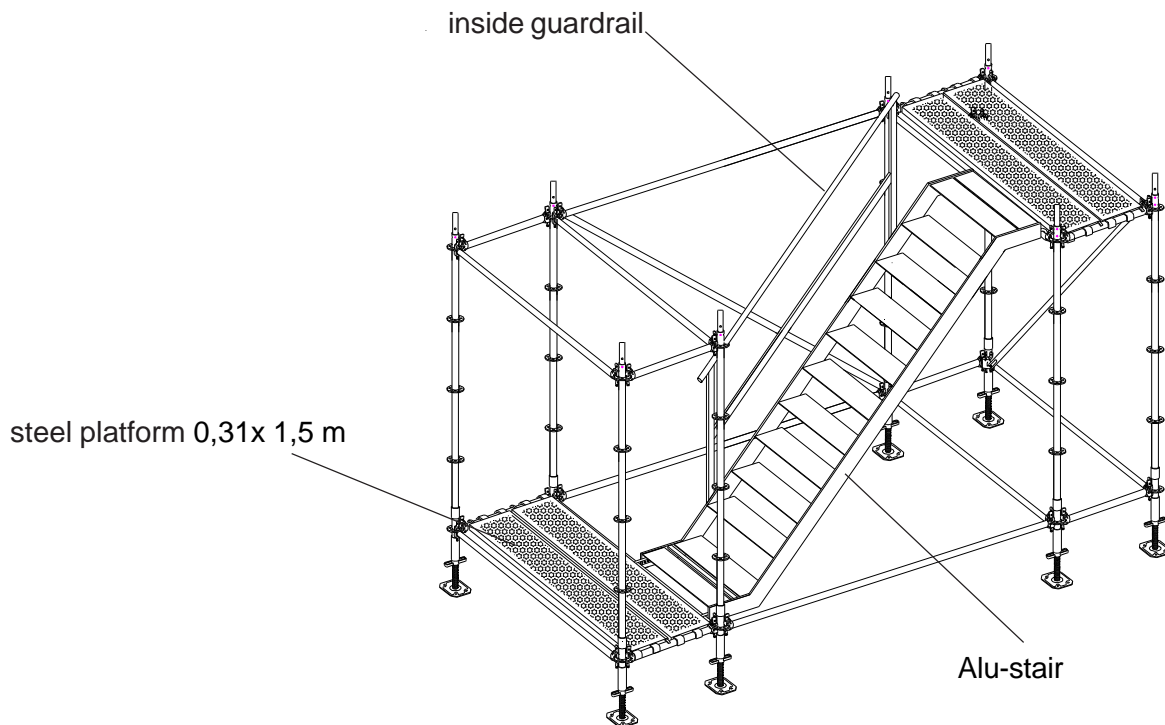

10.5.1.4 Fix 4 M-vertical posts 2,0 m respectively 3,0 m. 2 M-handrails, 1 M- horizontal ledgers 2,5 m  
2 M-horizontal ledgers 1,5 m, 4 M-horizontal ledgers 0,73 m, 1 M-diagonal braces 2,5 x 2,0 m  
and 1 M-diagonal braces 1,5 x 2,0 m

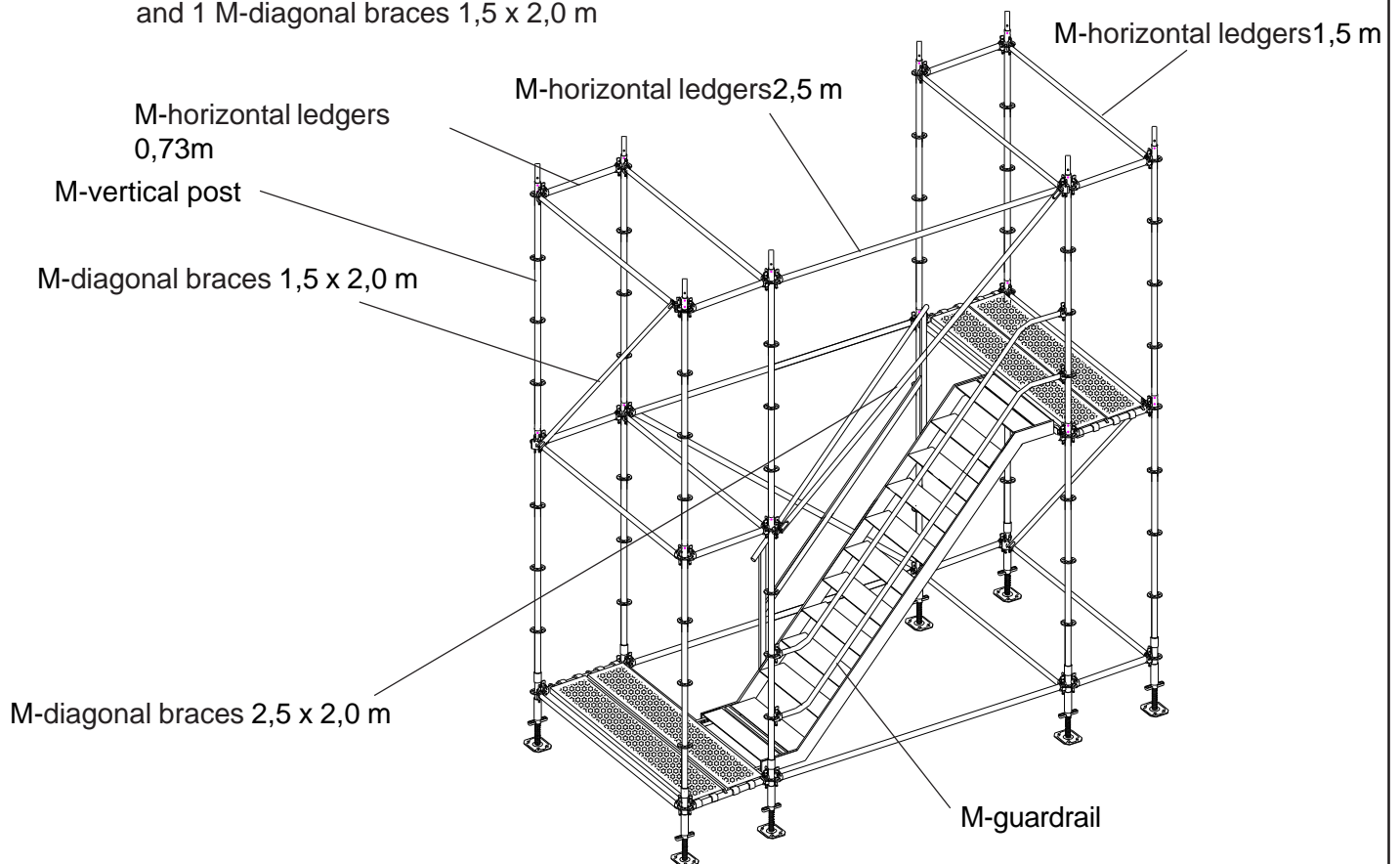

10.5.1.5 Assemble side protection with 2 M-horizontal ledgers 1,5 m and 4 M-horizontal ledgers 0,73 m, Alu stair, inside guardrail and 2 steel platforms 0,31 x 1,5 m

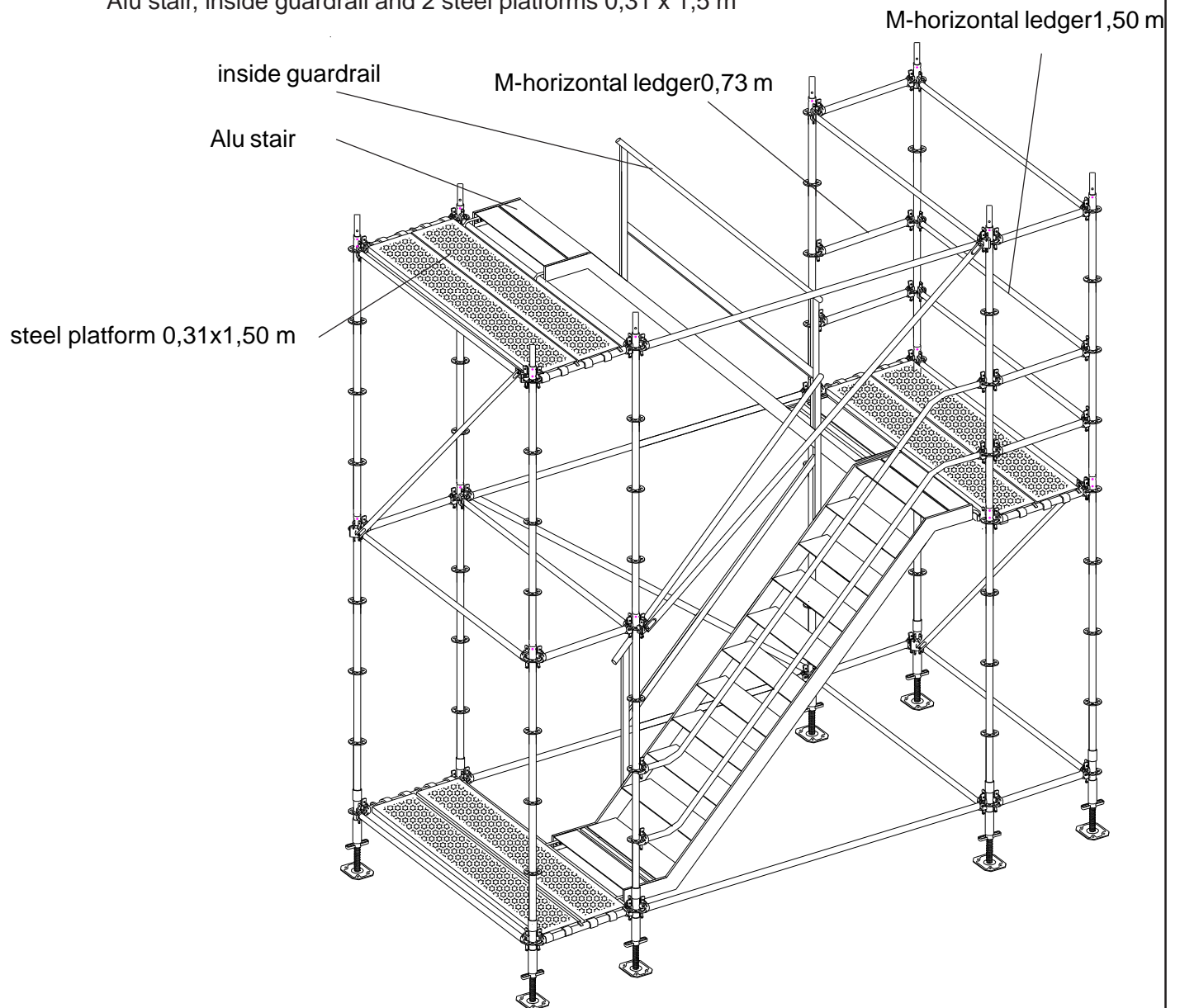

10.5.1.6 Repeat step 4 - 5 every 2 m.

*Need of material per floor:*

- 8 Vertical posts 2,0 m
- 6 Horizontal ledgers 1,5 m
- 8 Horizontal ledgers 0,73 m
- 5 Horizontal ledgers 2,5 m
- 1 Diagonal brace 2,5 x 2,0 m
- 1 Diagonal brace 1,5 x 2,0 m
- 1 Alu stair
- 1 Inside guardrail
- 2 M - guardrail

10.5.1.7 Stick together 4 M-vertical posts 2,0 m, 2 M-guardrail posts.  
 Connect with 2 M-guardrails, 6 M-horizontal ledgers 0,73 m,  
 4 horizontal ledgers 1,5 m, 1 diagonal brace 2,5 x 2,0 m,  
 1 diagonal brace 1,5 x 2,0 m

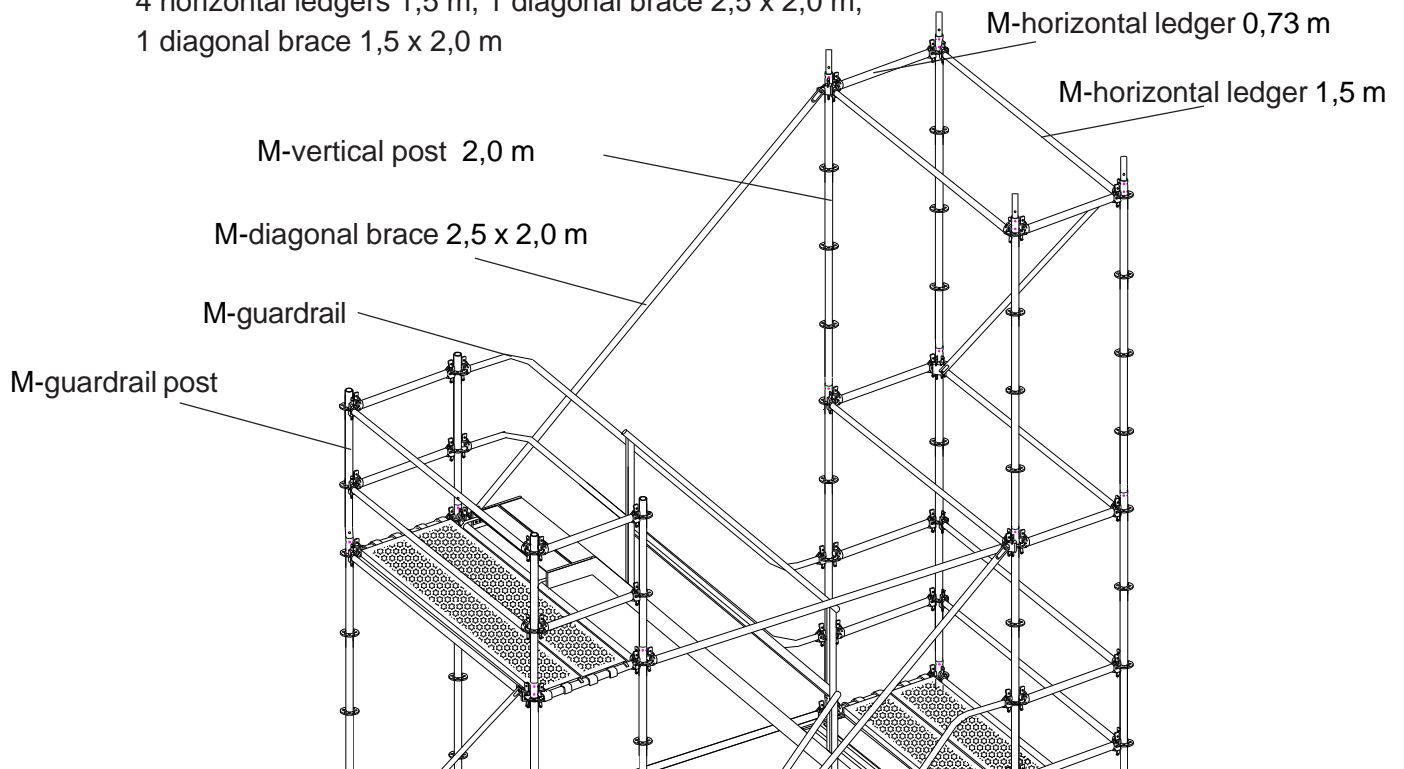

10.5.1.8 Fix Alu stair, inside guardrail, mount 2 steel platforms.

Fix 4 M-vertical posts .  
 Connect with 2 M-guardrails, 2 M-horizontal ledgers 1,5 m,  
 2 M-horizontal ledgers 0,73 m and M-end guardrail

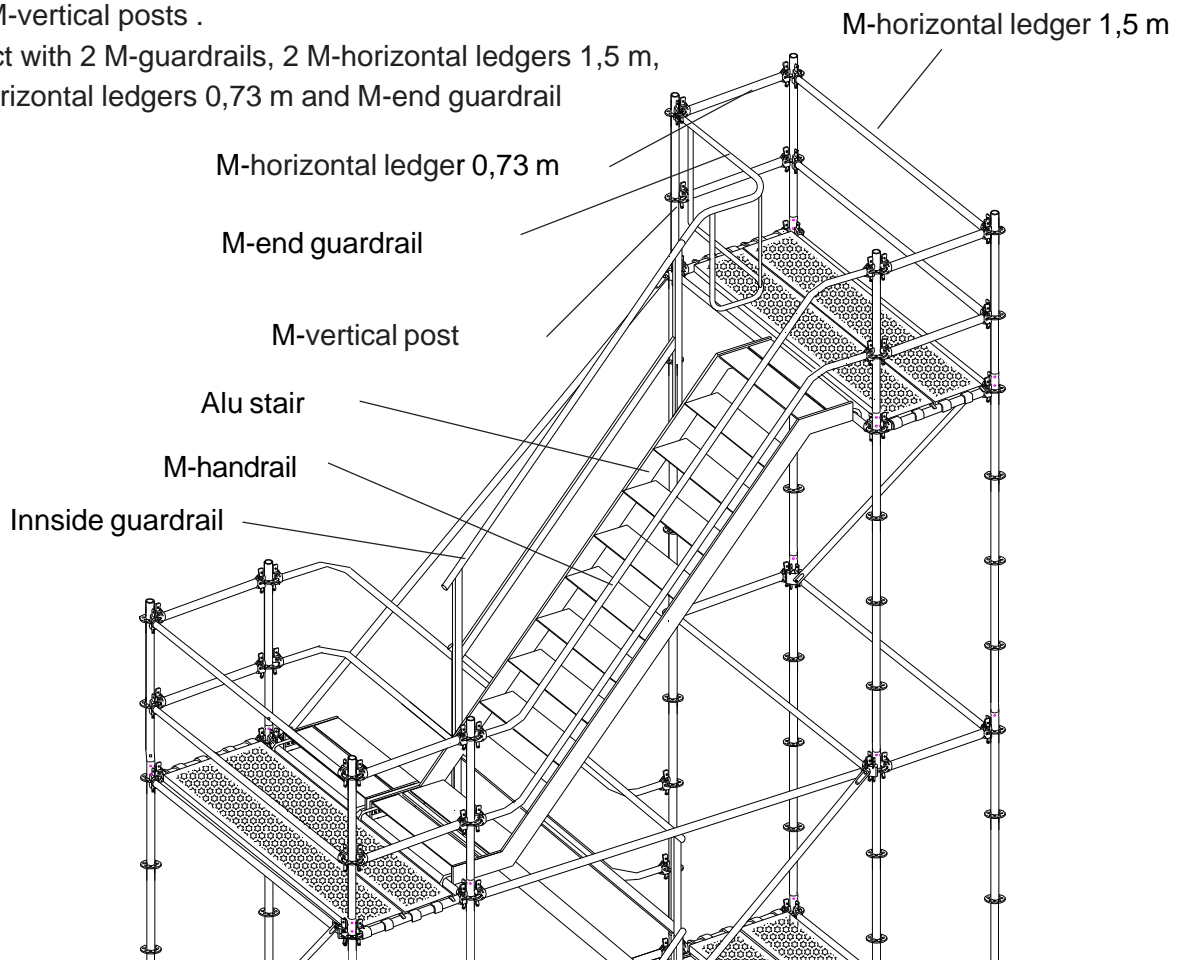

# 11. MATERIAL REQUIREMENTS

## 11.1 SCAFFOLDING STAIRTOWER STANDARD

Need of material for stairtower Standard

Exit height	guardrail post	M-vertical post 2,0m	starting tube	base plate 25/40	M-horizontal ledger 12,504	M-horizontal ledger 1,50m	M-diagonal brace 2,50m	M-diagonal brace 1,50m	Alu-stair 2,50	inside guardrail	M-handrail	M-end guardrail	anchor 0,6m	anchor 2,0m	coupler	weight
4,40m	4	6	4	4	3	7	2	2	2	2	4	1	2		2	322,00
6,40m	4	10	4	4	4	11	3	3	3	3	6	1	4		4	472,00
8,40m	4	14	4	4	5	15	4	4	4	4	8	1	4	2	6	634,00
10,40m	4	18	4	4	6	19	5	5	5	5	10	1	6	2	8	796,00
12,40m	4	22	4	4	7	23	6	6	6	6	12	1	6	2	8	939,00
14,40m	4	26	4	4	8	27	7	7	7	7	14	1	8	2	10	1.095,00
16,40m	4	30	4	4	9	31	8	8	8	8	16	1	8	4	10	1.262,00
18,40m	4	34	4	4	10	35	9	9	9	9	18	1	10	4	14	1.420,00
20,40m	4	38	4	4	11	39	10	10	10	10	20	1	10	4	14	1.564,00
22,40m	4	42	4	4	12	43	11	11	11	11	22	1	12	4	16	1.716,00
24,40m	4	46	4	4	13	47	12	12	12	12	24	1	12	6	18	1.885,00

## 11.2 SCAFFOLDING STAIRTOWER X-LARGE

Need of material for stairtower X-Large

Exit height	guardrail post	M-vertical post 2,0m	starting tube	base plate 25/40	M-horizontal ledger 12,504	M-horizontal ledger 1,50m	M-diagonal brace 2,50m	M-diagonal brace 1,50m	Alu-stair 2,50	inside guardrail	M-handrail	anchor 0,6m	anchor 2,0m	coupler	steel platform 1,50m	M-horizontal ledger 0,73m	M-end guardrail	weight
4,40m	8	12	8	8	3	14	2	2	2	2	4	2		2	6	18	1	588,00
6,40m	8	20	8	8	4	20	3	3	3	3	6	4		4	8	26	1	834,00
8,40m	8	28	8	8	5	26	4	4	4	4	8	4	2	6	10	34	1	1.080,00
10,40m	8	36	8	8	6	32	5	5	5	5	10	6	2	8	12	42	1	1.325,00
12,40m	8	44	8	8	7	38	6	6	6	6	12	6	2	8	14	50	1	1.571,00
14,40m	8	52	8	8	8	44	7	7	7	7	14	8	2	10	16	58	1	1.816,00
16,40m	8	60	8	8	9	50	8	8	8	8	16	8	4	10	18	66	1	2.062,00
18,40m	8	68	8	8	10	56	9	9	9	9	18	10	4	14	20	74	1	2.308,00
20,40m	8	76	8	8	11	62	10	10	10	10	20	10	4	14	22	82	1	2.555,00
22,40m	8	84	8	8	12	68	11	11	11	11	22	12	4	16	24	90	1	2.800,00
24,40m	8	92	8	8	13	74	12	12	12	12	24	12	6	16	26	98	1	3.050,00

# 12. ANCHORING

Anchors have to connect tower and building high tensile and pressure resistant to all sides.

Anchors shall not bear any vertical forces.

Position and quantity of anchors you will find in the table below.

Regardless of the anchoring pattern according to the table, you have to fix anchors at each exit or intermediary level.

Anchoring forces have to be transfered safely to the building.

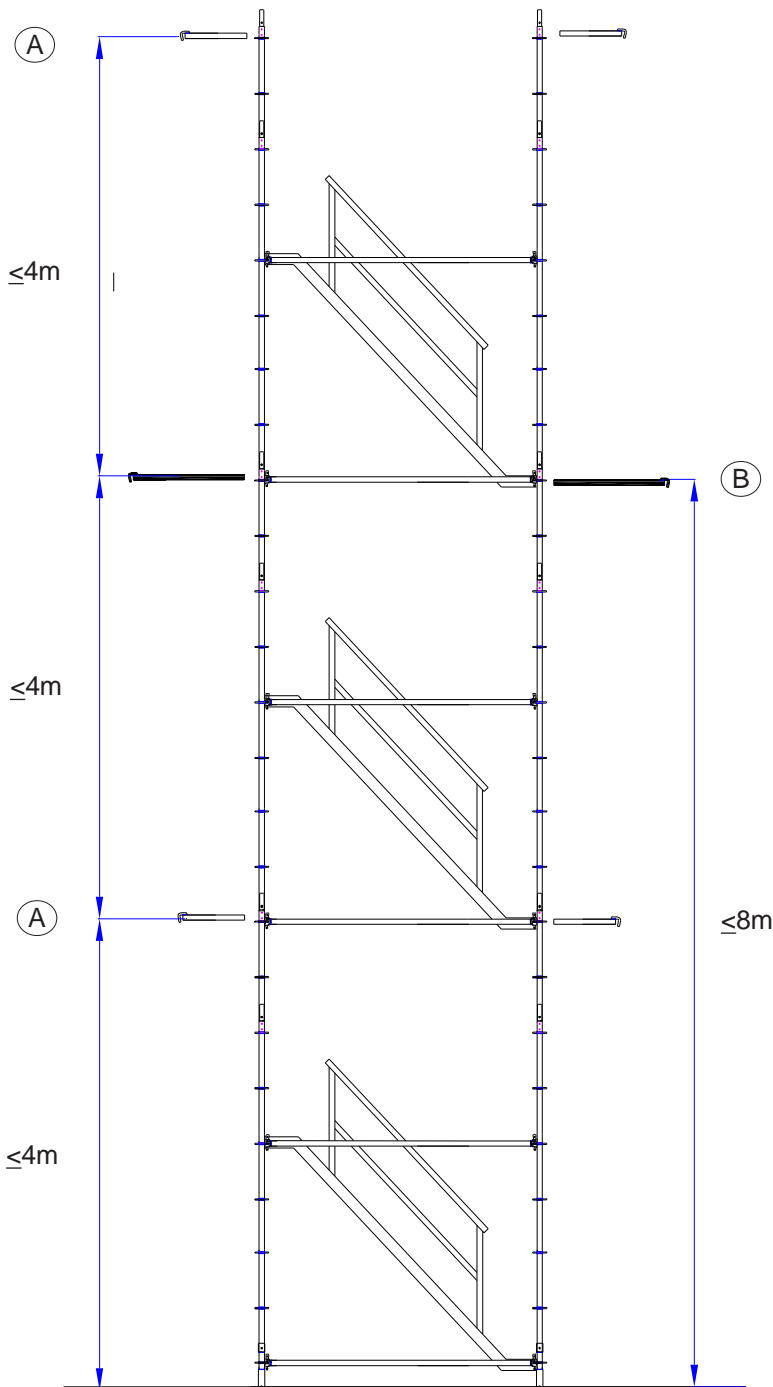

anchoring

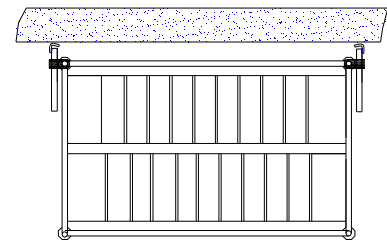

anchoring

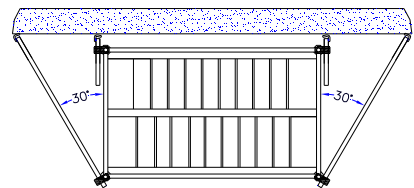

**anchoring with:**

**A** 2 anchors 0,6 m  
2 couplers

**B** 2 anchors 2,0 m  
2 anchors 0,6 m  
4 couplers

# 13. Components

## M - Vertical posts

ITEM	ART. NR.	WEIGHT
M - Vertical post 0,5 m galvanized	80001	3,00 kg
M - Vertical post 1,0 m galvanized	80002	5,40 kg
M - Vertical post 2,0 m galvanized	80003	10,00 kg
M - Vertical post 3,0 m galvanized	80004	14,80 kg
M - Vertical post 4,0 m galvanized	80005	19,30 kg

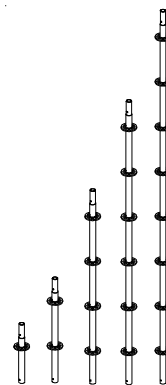

## M - Starting tube and guardrail post

ITEM	ART. NR.	WEIGHT
M - starting tube 0,4 m galvanized	80010	1,80 kg
M - guardrail post 1,1 m galvanize	80015	5,00 kg

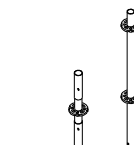

## M - Horizontal ledgers

ITEM	ART. NR.	WEIGHT
M - Horizontal ledger 0,73 m galvanized	80020	3,00 kg
M - Horizontal ledger 1,0 m galvanized	80021	4,00 kg
M - Horizontal ledger 1,25 m galvanized	80022	4,80 kg
M - Horizontal ledger 1,5 m galvanized	80023	5,70 kg
M - Horizontal ledger 2,0 m galvanized	80024	7,60 kg
M - Horizontal ledger 2,5 m galvanized	80025	9,60 kg
M - Horizontal ledger 2,504 m galvanized	80026	9,60 kg
M - Horizontal ledger 3,0 m galvanized	80027	11,40 kg

System Ringer

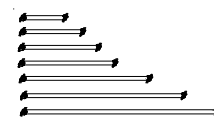

## M - Diagonal braces

ITEM	ART. NR.	WEIGHT
M - Diagonal brace 0,73 x 2,0 m galvanized	80030	6,50 kg
M - Diagonal brace 1,0 x 2,0 m galvanized	80031	7,50 kg
M - Diagonal brace 1,25 x 2,0 m galvanized	80032	7,80 kg
M - Diagonal brace 1,5 x 2,0 m galvanized	80033	8,00 kg
M - Diagonal brace 2,0 x 2,0 m galvanized	80034	8,90 kg
M - Diagonal brace 2,5 x 2,0 m galvanized	80035	9,90 kg
M - Diagonal brace 3,0 x 2,0 m galvanized	80036	11,00 kg

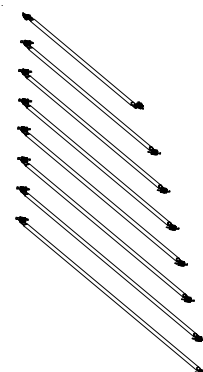

## M - Supporting bars

ITEM	ART. NR.	WEIGHT
M - Supporting bar 1,5 m galvanized	80054	9,60 kg
M - Supporting bar 2,0 m galvanized	80055	12,30 kg
M - Supporting bar 2,5 m galvanized	80056	15,40 kg
M - Supporting bar 3,0 m galvanized	80057	18,50 kg
M - Supporting bar for platform 0,73 m galvanized	80051	3,00 kg

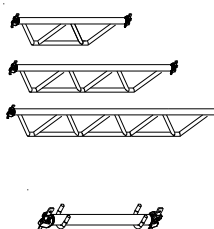

## Brackets

ITEM	ART. NR.	WEIGHT
M - Bracket 0,73 m galvanized	80071	3,00 kg
M - Bracket 0,42 m galvanized	80072	3,80 kg

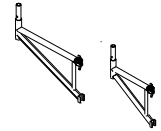

## Steel platforms

ITEM	ART. NR.	WEIGHT
Steel platform 0,315 x 0,73 m galvanized with protection agaist lifting	80060	8,00 kg
Steel platform 0,315 x 1,0 m galvanized with protection agaist lifting	80061	10,40 kg
Steel platform 0,315 x 1,5 m galvanized with protection agaist lifting	80062	13,00 kg
Steel platform 0,315 x 2,0 m galvanized with protection agaist lifting	80063	16,60 kg
Steel platform 0,315 x 2,5 m galvanized with protection agaist lifting	80064	19,90 kg
Steel platform 0,315 x 3,0 m galvanized with protection agaist lifting	80065	23,20 kg

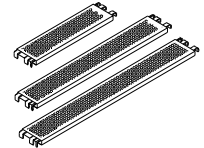

## Wooden and aluminium platforms System Ringer

ITEM	ART. NR.	WEIGHT
Wooden platform 0,6 x 0,72 m (red) solid wood	111 05	8,00 kg
Wooden platform 0,6 x 1,25 m (red) solid wood	111 13	13,00 kg
Wooden platform 0,6 x 1,50 m (red) solid wood	111 17	16,50 kg
Wooden platform 0,6 x 2,00 m (red) solid wood	111 16	22,50 kg
Wooden platform 0,6 x 2,50 m (red) solid wood	111 2	26,00 kg
Wooden platform 0,3 x 1,25 m (45 mm red) solid wood	100 03	7,50 kg
Wooden platform 0,3 x 1,50 m (45 mm red) solid wood	100 06	8,50 kg
Wooden platform 0,3 x 2,00 m (45 mm red) solid wood	100 05	11,50 kg
Wooden platform 0,3 x 2,50 m (45 mm red) solid wood	100 02	14,40 kg
Wooden platform 0,3 x 3,00 m (48 mm red) solid wood	100 01	18,00 kg
Aluminium platform 2,5 m with trap door and integrated ladder (200 kg/m <sup>2</sup> ) inner ascent	120 2	24,00 kg

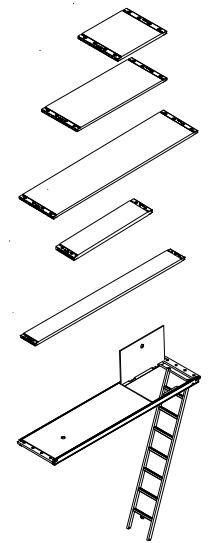

## Base plates

ITEM	ART. NR.	WEIGHT
Base plate 25/40 cm galvanized Adjustment up to appr. 25 cm; Plate surface 15 x 15 cm	132V0005	3,50 kg
Base plate 45/60 cm galvanized Adjustment up to appr. 45 cm; Plate surface 15 x 15 cm	132V0018	4,10 kg
Base plate 60/80 cm galvanized Adjustment up to appr. 60 cm; Plate surface 15 x 15 cm	132V0006	5,00 kg
Base Top plate	200V63	4,50 kg

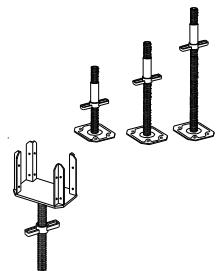

## Bridging beams

ITEM	ART. NR.	WEIGHT
Bridging beam 5,10 m galvanized height 0,45 m	113V51	49,00 kg
Bridging beam 7,60 m galvanized height 0,45 m	113V76	73,00 kg
Tube connector ø38 x 450 mm for bridging beam with screws galvanized	113V0	2,00 kg

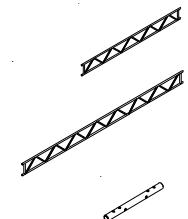

## Tubes

ITEM	ART. NR.	WEIGHT
Tube 48,3/2,3mm galvanized 6 m long	115V0011	2,60 kg/m
Tube 48,3/3,2mm galvanized 6 m long	115V0012	3,80 kg/m

## Ascent

ITEM		ART. NR.	WEIGHT
M - End guardrail galvanized	for highest floor	80080	4,50 kg
Inside guardrail for ladder 0,6 m galvanized	only for Alu - ladder	80081	10,00 kg
Alu - ladder width 0,6 m		80082	27,00 kg
M - handrail 2,5 m galvanized		80083	7,00 kg
Alu - ladder width 1,0 m		800821	35,00 kg
Inside guardrail for ladder 1,0 m galvanized	only for Alu - ladder	800811	12,50 kg

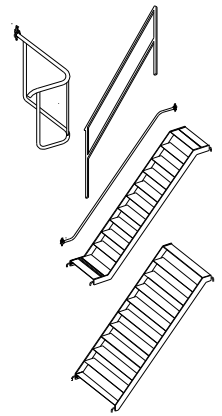

## Couplers for tubes ø 48,3mm

ITEM		ART. NR.	WEIGHT
Swivel coupler galvanized	SW 22	113V0012	1,50 kg
Right angle coupler galvanized	SW 22	113V0013	1,40 kg
Coupler for connecting tubes (in length) galvanized	SW 22	113V0014	1,70 kg
Swivel wedge coupler galvanized		115V0009	1,60 kg
Right angle wedge coupler galvanized		115V0010	1,50 kg
Wedge coupler for connecting tubes (in length) galvanized		115V0008	1,20 kg

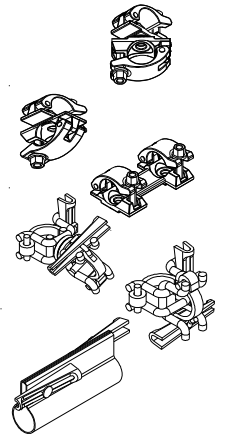

## Additional accessories

ITEM		ART. NR.	WEIGHT
M - Safety device against platforms and toe boards uplift galvanized		81001	0,90 kg
Bearing rail for platform 0,6 m galvanized		81004	4,00 kg
Bearing rail for platform 1,2 m galvanized		81006	7,00 kg
M - Safety bolts ø 10 mm galvanized		81007	0,15 kg
M - Base plate safety lock galvanized		81008	0,35 kg
Wedge coupler for board bearer galvanized		290V42	0,80 kg

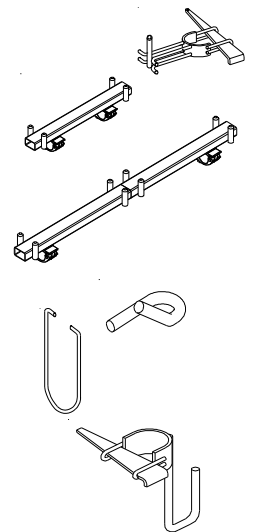

## Anchoring

ITEM		ART. NR.	WEIGHT
Anchor 0,6 m galvanized	Anchor to be fixed with 1 coupler	112V0008	2,40 kg
Anchor 1 m galvanized		290V0048	2,90 kg
Anchor 1,5 m galvanized	long anchor to be fixed with 2 couplers	112V0001	5,30 kg
Anchor 2 m galvanized		112V2	7,90 kg
Screw with safety head 18 cm galvan.	shaft length 18 cm	290V0069	0,22 kg
Screw with safety head 25 cm galvan.	shaft length 25 cm	290V0070	0,25 kg
Screw with safety head 30 cm galvan.	shaft length 30 cm	290V0071	0,30 kg
Fischer dowel S 16	for all anchoring	290 0011	0,11 kg per carton

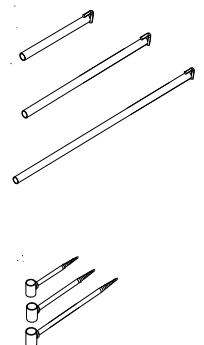

## 14. EXAMPLES





**RINGER Modular scaffolding for**

# **universal application**



Central office and production in REGAU, AUSTRIA

Contact

Römerweg 9  
A-4844 Regau, Austria  
Telefon: +43 (0) 7672/72711-0  
Fax: +43 (0) 7672/78805  
E.mail: [office@ringer.at](mailto:office@ringer.at)  
[www.ringer.at](http://www.ringer.at)