



# Instructions for Assembly and Use **Speedy Scaffolding**



[www.ringer.cc](http://www.ringer.cc)



**RINGER**  
GERÜSTE + SCHALUNGEN



CONTENT	PAGE
I) PRODUCT DESCRIPTION	2
II) SCAFFOLDING ASSEMBLY	3
2.1 General Information	3
2.2 Assembly of the first field	3
2.3 Assembly of further fields	5
2.4 Scaffolding Assembly	7
2.5 Assembly Variants	10
III) DISASSEMBLY OF SCAFFOLDING	15
IV) USAGE	15
V) DIFFERENT ASSEMBLY OPTIONS	15
VI) SET-UPS	16
VII) LIST OF ARTICLES	25

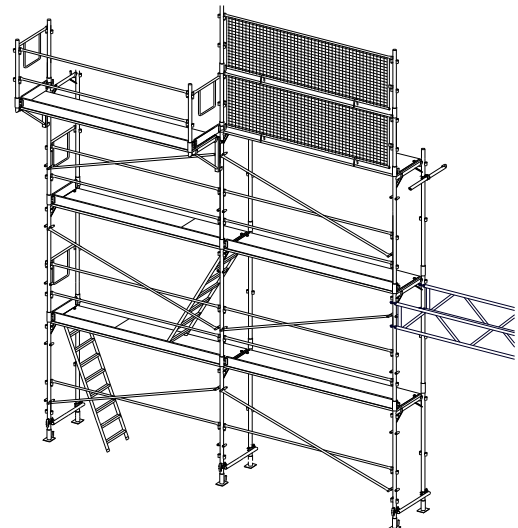

**General Information**

The products produced by company RINGER  
 + conform with standards of Building Rules List A  
 + subject to production control (intake, intermediary and end control) according to DIN18200 /ISO 9001  
 + certification of material according to EN 10204.  
 Welding production is certified according to ÖNORM EN1090.EXC2

**Usage**

The User Manual is addressed to the personnel, who works with the described products and contains information about the mounting and usage.  
 The instruction gives basic principles of the mounting and assembly, though it does not replace the evaluation  
 Drawings presented in this User Manual have to be adjusted according to specific safety regulations of each country

**Assembly**

The customer has to ensure, that assembly and disassembly is done under control of experienced personnel.  
 The material has to be inspected before usage. Damaged or deformed parts should not be used!  
 Mixing with system parts from other manufacturers can lead to health and material damages and is a subject to special inspection.

**Working Protection**

For the safe usage please pay attention to local safety regulations!

## I) PRODUCT DESCRIPTION:

### 1.1 General Information:

Ringer Speedy Scaffolding (SB) is a steel framed scaffolding system using pre-fabricated parts with system width of 0.65 m. Standard field length is 2.5 m. Other field length for distance compensation is possible: 0,72, 1,25, 1,5, 2,0 and 3.0 m. Vertical frames have a height of 2 m and this determines the intervals between working levels.

Frames are fitted one above the other in welded-on coupling sockets. Horizontal and diagonal braces are fitted into lugs, welded to scaffolding frames and secured with locking plates.

Platforms (*solid wood, steel or aluminium platforms*) are held in place horizontally by *pins* on the crossbeams and thus strengthen the scaffolding both at right angles to and parallel to facade.

Ringer Speedy Scaffolding (SB) comply with the requirements of Height Class H1, Width class W06 according to DIN EN 12811-1 and is specified as scaffolding class 3 with bearing capacity 200 kg/m<sup>2</sup> and may be used as protective (catch) scaffolding for a max of 2 m drop height. (*Higher load capacity class is possible by certain assembly versions. Please contact company Ringer for further information*)

The top scaffolding level in standard assembly option should be placed at max 24 m height plus length of base jacks.

Maximal working height with special assembly options is 100 m.

Production and marking of construction parts complies with European Standard EN12810-12812

SB scaffolding complies with Austrian standard ÖNORM B4007 and safety regulations for construction works!

### 1.2 Assembly and Disassembly:

Assembly and disassembly of Ringer Scaffolding should only be undertaken by persons with sufficient special knowledge.

### 1.3 Deviations:

Standard assembly and disassembly rules are described in this Manual. In case of any deviations from the standard assembly/disassembly variant, these deviations have to meet the demands of construction regulations, correspond to requirements of construction authorities and should be evaluated in each separate case.

### 1.4 Inspection and Documentation:

SB scaffolding should be inspected after each usage by authorized person. The record of the results of this inspection should be kept accordingly.

Not approved parts should be marked (Access prohibited)

Approval note should be attached on scaffolding. It should show the information about scaffolding manufacturer, load capacity class.

The approval should be properly recorded!!

### 1.5 Usage of Platforms:

Item	Usage as protection and catching scaffolding	Field length	Scaffolding group max. load capacity
Platform wood	allowed	0,72-2,0 m	<3 200kg/m <sup>2</sup>
Platform wood	not allowed	2,5 m	<3 200kg/m <sup>2</sup>
Platform wood "S"	allowed	2,5 m	<3 200kg/m <sup>2</sup>
Alu-platforms with trap door and integrated ladder	allowed	2,5 m	<3 200kg/m <sup>2</sup>
Platform all-over aluminium	allowed	2,5 m 3,0 m	<5 450Kg/m <sup>2</sup> <3 200Kg/m <sup>2</sup>
Platform steel	allowed	2,5 m 3,0 m	<4 300kg/m <sup>2</sup> <3 200kg/m <sup>2</sup>

## **1.6 Safety Information:**

- Scaffolding parts should be checked before usage for any visible defects.
- Each user is responsible for the usage of SB scaffolding according to regulations and safety rules.
- Scaffolding should be constantly controlled for defects caused by construction work and outer influence
- Access, ascent on scaffolding should be done only in designated areas.
- It is forbidden to climb on scaffolding and jump from it.
- Access on scaffolding is not allowed for non authorized personnel.
- It is forbidden to access scaffolding under alcohol or drug influence
- It is forbidden to jump or to through anything on scaffolding platforms.
- Trap doors of access platforms should be closed during construction work.
- It is not allowed to step or to store any material on protection roof.
- When scaffolding is used as catching or protective scaffolding no construction material or tools should be stored in protection area.
- The user of scaffolding should not dismantle any side protection or change anything in anchoring scheme.
- After assembly according to basic variant no lifting or other devices as well as no protection

## **II) Assembly:**

### **2.1 General Requirements:**

#### **2.1.1 System parts:**

- The structural parts should be checked to ensure that they are in perfect condition by a controller who should be constantly present during the work. Damaged scaffolding parts must not be used in structure assembly.
- All the regulations are valid only when original system parts of Ringer scaffolding are used. The usage of other system components can cause safety problems and can lead to insufficient stability.
- Scaffolding assembly (scaffolding set-up variants) is effected according to DIN EN 12811-1 as well as to this User Manual.

#### **2.1.2 Assembly and disassembly:**

The assembly and disassembly of Ringer Speedy Scaffolding System should be made in the succession described below.

### **2.2 Assembly of the first scaffolding field:**

#### **2.2.1 Load-distributing sub-structure:**

Ringer Speedy Scaffolding may only be erected on surfaces with sufficient bearing capacity, for example  $p > 150 \text{ kN/m}^2$ . Where ground with sufficient bearing capacity is not available the provision of a weight distributing base is foreseen (fig.1)

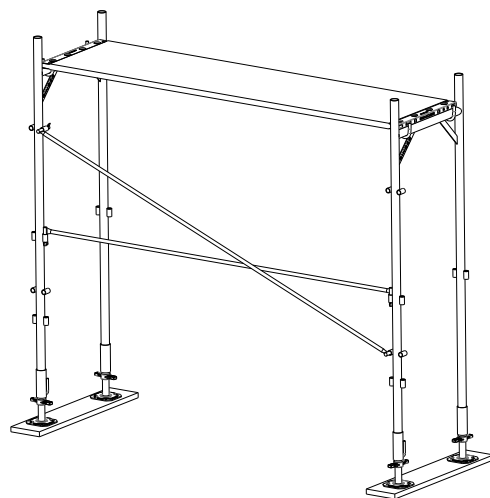

**Fig 1:** Load-distributing sub-structure with planks

### 2.2.2 Base plates, adjustable base plate:

A foot plate or adjustable base plate is to be placed beneath each scaffolding stand (Fig. 2). In case when adjustable plate is screwed out more than **25 cm**, **board bearer** should be fixed!!

### 2.2.3 Ground offset:

When the ground is not even, there are differences in height or in order to achieve certain scaffolding height, height adjustment is made in the following way (fig 2). As long as these cases are nonstandard assembly versions, additional anchoring and stiffening can be required.

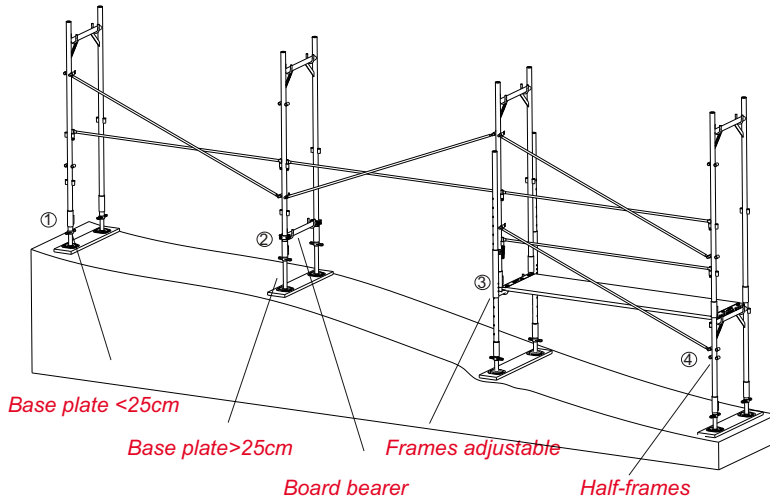

**Fig 2: Ground offset**

- 1) Adjustable base plate up to 25cm
- 2) Adjustable base plate up to 60cm board bearer
- 3) Adjustable frames (up to 180cm)
- 4) Halfframes (up to 100 cm)
- 5) Adjustable leg, safety bolt and base plate for adjustable leg

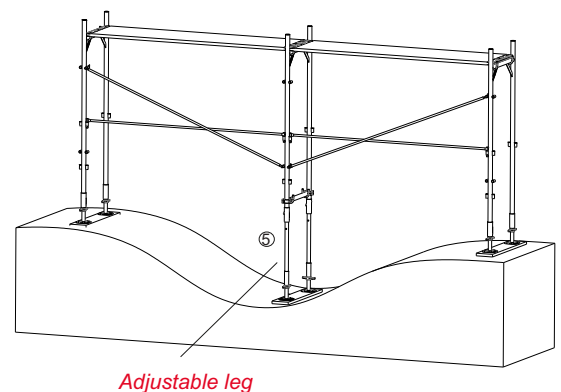

### 2.2.4 Scaffolding frames:

Vertical frames and passage frames should be set vertically at a certain distance from the wall (max. 30cm) on (adjustable) base plates and to be secured against accidents (fig. 3).

Horizontal and diagonal brace as well as platform should be mounted for stability (assembly help) or to straighten the lowest scaffolding level

The first scaffolding field is aligned vertically and horizontally by adjusting the base plate

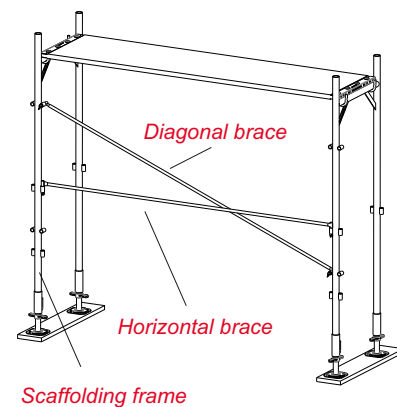
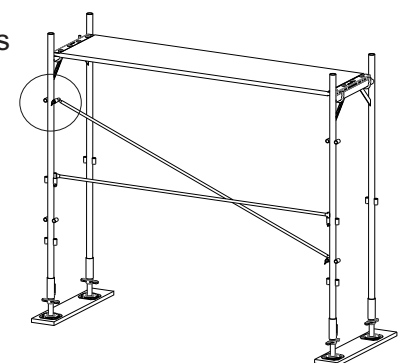
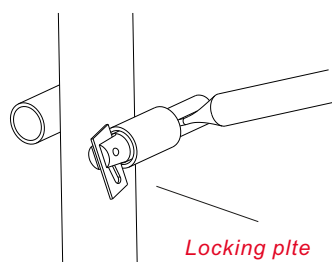

**Fig 3: Assembly of the first field**

### 2.2.5 Braces (horizontal and diagonal):

Horizontal brace for connection and diagonal brace from inside to outside for stiffening should be fitted to outside tubes of scaffolding frame.

After braces are fitted into lugs, they should be secured with locking plates (see Detail)!



**Detail: Securing of braces**

### 2.2.6 Placing platforms:

Only Ringer system platforms should be used. The width of each field is 60 cm, thus per field 60 cm wide aluminium or wooden platform are to be fitted. They are held in place horizontally by pins on the crossbeams and thus strengthen scaffolding both at right angles to and parallel to facade. Platforms fulfill static function, they should be fitted also if they are not used. Platforms are protected against uplift due to frames that are fixed on the next level.

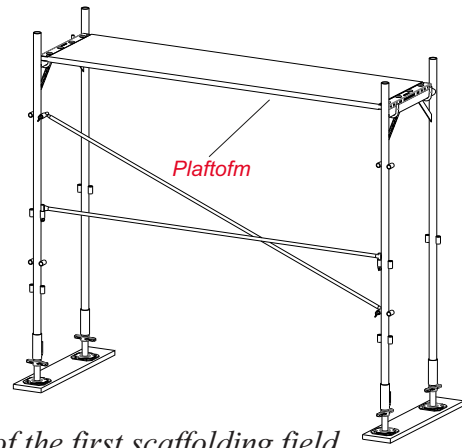
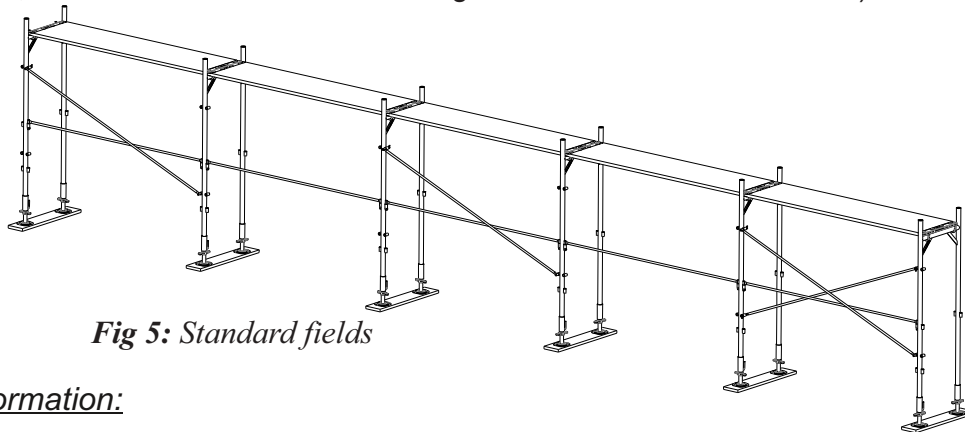

*Fig 4: Completion of the first scaffolding field*

## 2.3 Assembly of further scaffolding fields

### 2.3.1 Standard field:

Standard field has a length of **2,5 m!**  
As distance compensation following field lengths are also possible: **3,0 / 2,0 / 1,5 / 1,25 0,73 and 0,65m.**  
The further scaffolding fields are assembled as described above.  
Diagonal braces should be fitted in according to assembly option (on the lowest level minimum 1 brace in each second field, otherwise in each fifth field 2 diagonal braces should be fitted in)



*Fig 5: Standard fields*

### 2.3.2 Corner formation:

The two adjacent frame tubes should be connected together with swivel couplers.  
At the lowest level 2 swivel couplers per frame are used. For the levels above at vertical intervals of maximum 4 m swivel coupler should be used at each anchoring level. One base plate less is required. Corner anchor replaces rim anchor.

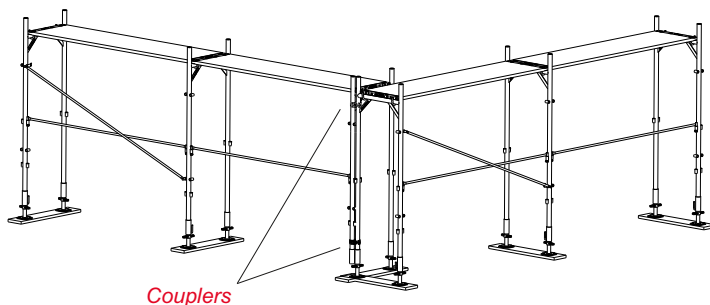

*Fig 6a: Inside corner*

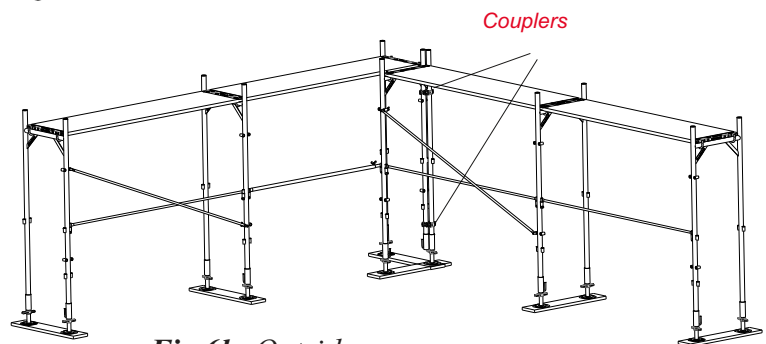

*Fig 6b: Outside corner*

### 2.3.3 Scaffolding ascent:

*Scaffolding ascent should be assembled into the structure from the first level up!*

In accordance with norm ÖNORM B4007 by large volume of material transportation and by work in the roof area starting from level height of 10 m working area and transportation roots should be separated.

#### Inside ascent with Alu Platform with trap door and ladder

Alu platforms should be fitted in so that the ladders are placed left and right in the appropriate fields (Fig 7a)  
As support of the ladder on the ground level board bearer or any stabilizer should be used (Fig 7b)  
In case of longer facades, working place on scaffolding should be placed max. 20 m away from a ladder.  
Trap doors should be opened only to climb through and should be closed again immediately!

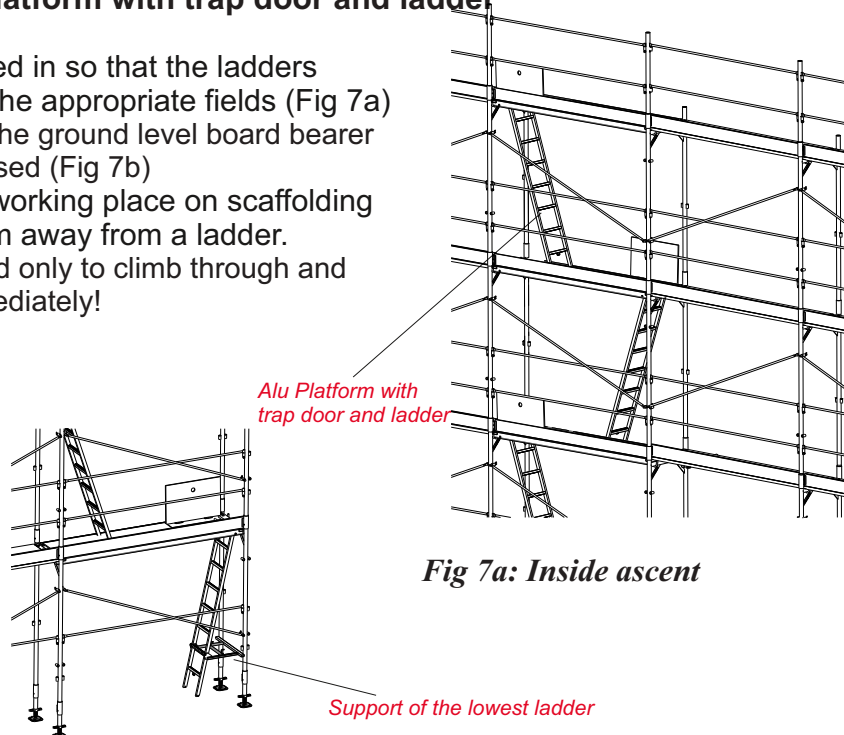

**Fig 7a: Inside ascent**

#### Fig7b: Support of ladder

### Scaffolding ladder

For easy access to scaffolding a separate ladder can be assembled in front of scaffolding field

#### Assembly:

- Fix frames with couplers to the chosen scaffolding field (first frame with 2 couplers, each further with one coupler)
- Hang alu ladder on the frames.
- Fix 2 handrails per ladder for protection
- Fix 0,65 guardrails for protection + additional middle level guardrail bar on the side of passage to scaffolding. (for example board bearer or tube with couplers)
- Make the top level safe with brackets and adjustable brace
- If necessary fix additional guardrail on the inner side of the ladder.

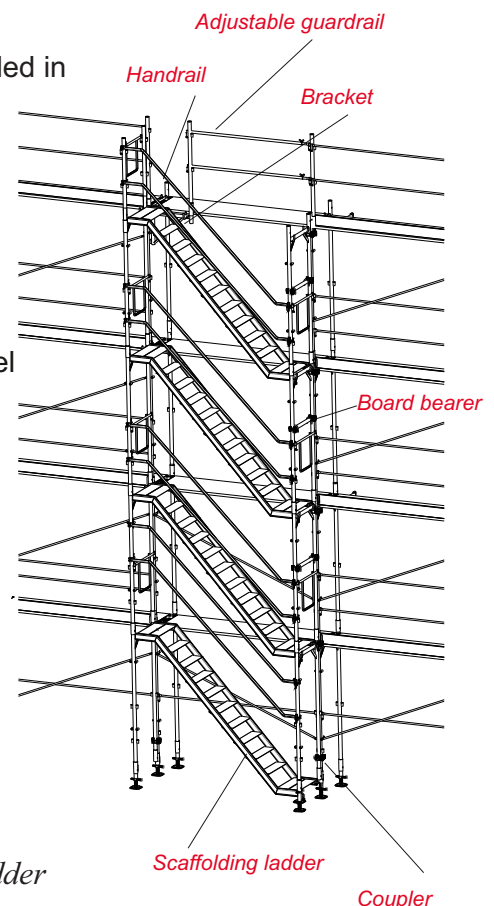

**Fig7c: Scaffolding ladder**

## 2.4 Assembly of further scaffolding fields

### 2.4.1 General info:

- Assembly of scaffolding should be carried out so that the danger of falling accidents is as low as possible.
- In single cases risk assessment should be done and corresponding measures taken.
- The scaffolding structure is to be continuously anchored as it is assembled!

### 2.4.2 Transportation of scaffolding parts

For scaffolding structures with a height above 8 m construction lifts must be used for assembly/disassembly. Construction lifts include also hand operated cable pulley lifts.

*Attention: frames to which cable pulley lift is fixed should be anchored!!*

As a deviation to this instruction: it is possible to assemble without the use of construction lifts when scaffolding height is not more than 14 m and the length of the scaffolding is not more than 10 m. In fields where vertical transport is to be carried out by hand, horizontal brace should be fixed. **It is allowed to enter max one field without side protection** (Fig 8 and 9).

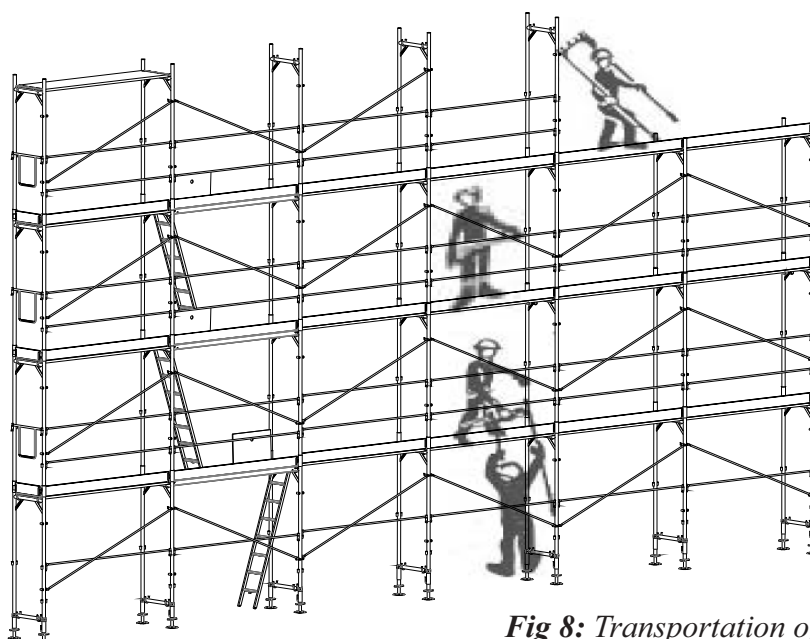

*Fig 8: Transportation of scaffolding parts*

### 2.4.3 Bracing (Horizontal and diagonal braces)

Horizontal and diagonal braces stiffen scaffolding structure.

*First scaffolding field:* 1 Horizontal brace (chest level) + Diagonal brace according to assembly option.

*Further scaffolding fields:* 2 Horizontal braces (chest and middle level) + Diagonal brace according to assembly option.

*Top level:* 2 Horizontal braces (chest and middle level)

***Attention: in case scaffolding levels are not used for work, the middle bracing is not necessary from a statical point of view. Toe boards can be avoided as well. Identification marking of these levels is required!***

### 2.4.4 Completion of side protection:

- 1) - Missing guardrail posts, horizontal braces and toe boards as well as side guardrails 0,65m should be placed in all scaffolding levels of Ringer Speedy Scaffolding.
- Fix toe board to pins provided. (Toe boards must also be fitted to protective roofing and catching scaffolding).
- At the top level guard rail posts must be fitted, wooden platforms should be secured additionally against uplift (wind)
- On the side either a frame or 2 guardrail posts with side guardrail 0,65 should be fixed (accord. to Fig 10a).

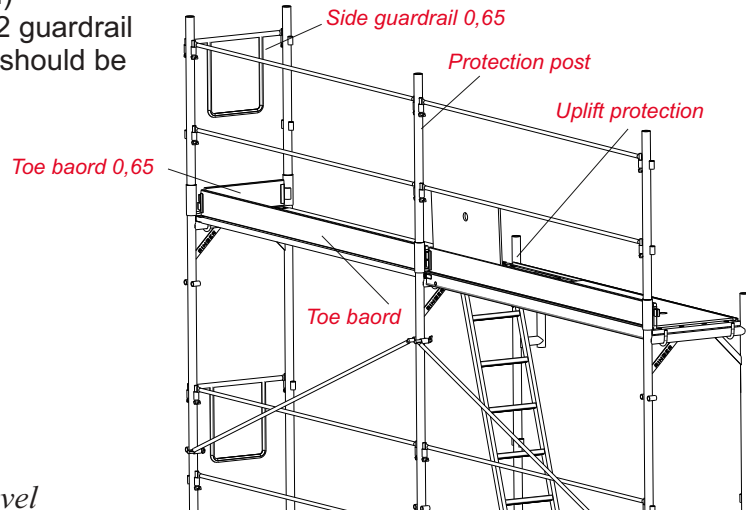

**Fig 10a:** Side protection on the top level

- 2) - When the distance between scaffolding platform and the wall is more than 30 cm guardrail with toe, middle and top level protection should be fixed on inner side of scaffolding (up to 40 cm is allowed as exception for very structured facades, when insulation material reduces distance to facade for at least 10 cm)

- Inner guardrails should be fixed with wedge couplers with 2 lugs or fastener for inside guardrail

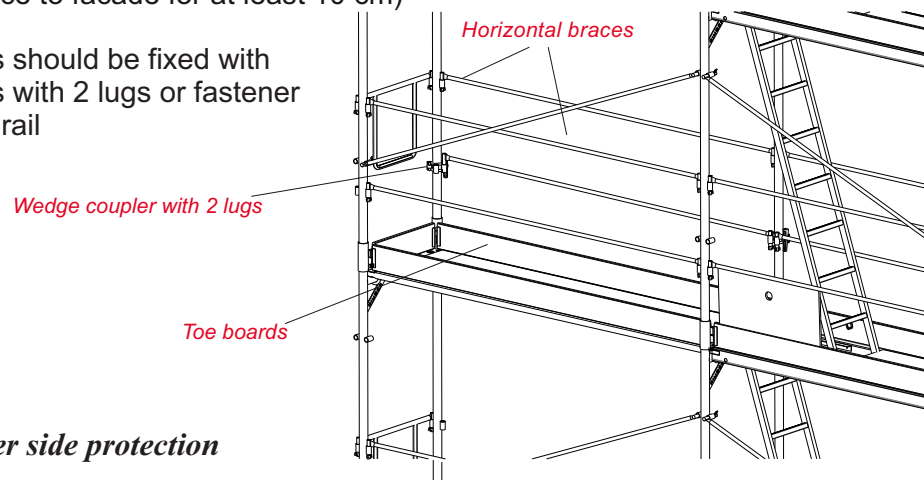

**Fig 10b:** Inner side protection

### 2.4.5 Anchoring (anchor pattern and anchor forces):

- Anchor pattern and anchoring forces depend on assembly variant.
- Data for anchoring required for roof protection and catching scaffolding with brackets 0.6 m and protection roof is given in section 2.5.
- Anchoring should be made continuously during assembly of scaffolding. Maximal 2 scaffolding levels may be assembled without anchoring. Use collar or scaffolding screws for fixing (diameter min. 12 mm).
- Anchoring forces are carried out by anchors and fixing parts, the anchors should be fixed in walls with sufficient bearing capacity (brick, reinforced concrete walls).
- Take care of bearing capacity!!
- Confirmation of bearing capacity can be done by: technical approval, calculations or tests.

## 2.4.6 Anchors:

- Anchors are to be fitted close to knot points (intersection of tubes and platforms). Standard couplers according to DIN EN 74 should be used for the joints. (In exceptional cases anchors can be fixed at a distance of maximum 40 cm from knot points (= intersections). The length of the anchors can differ from 0,6-2,0m.

### Anchor 0,6m (Fig 11)

It should be fixed only to inner tube of scaffolding frame. The anchoring force is at right angle to facade.

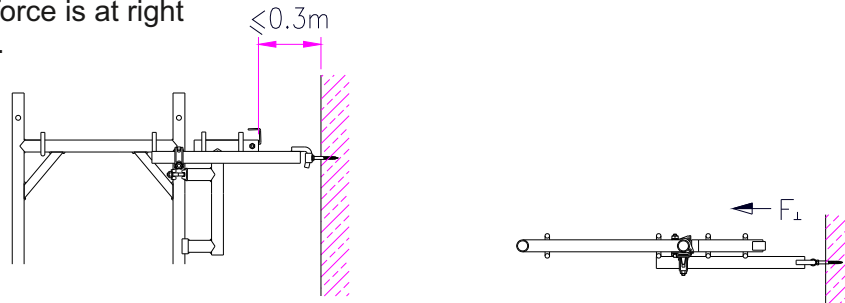

**Fig 11: Anchor 0,6m**

### Long anchor 1,0-2,0 Meter (Fig 12)

Long anchors are fixed to both tubes of scaffolding frame

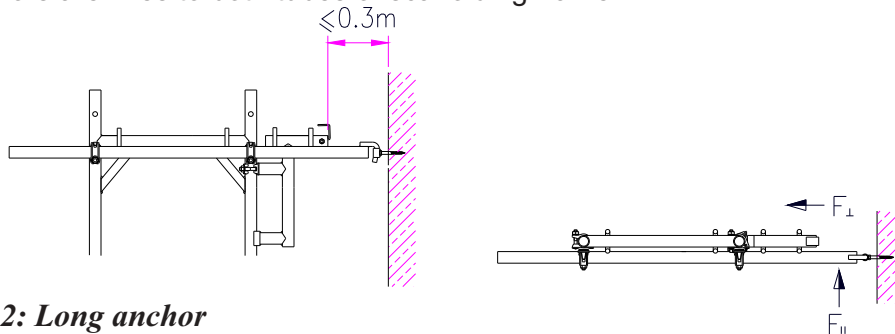

**Fig 12: Long anchor**

### V-anchor (Fig 13)

V-anchors are fixed only to the inner tubes. The anchoring force is at right angle and parallel to the facade.

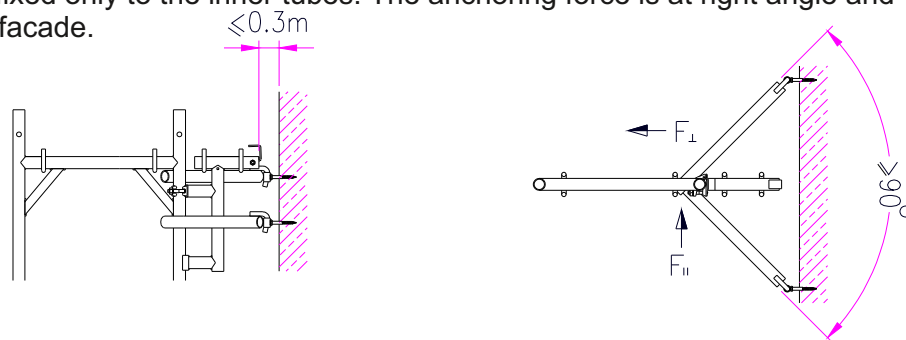
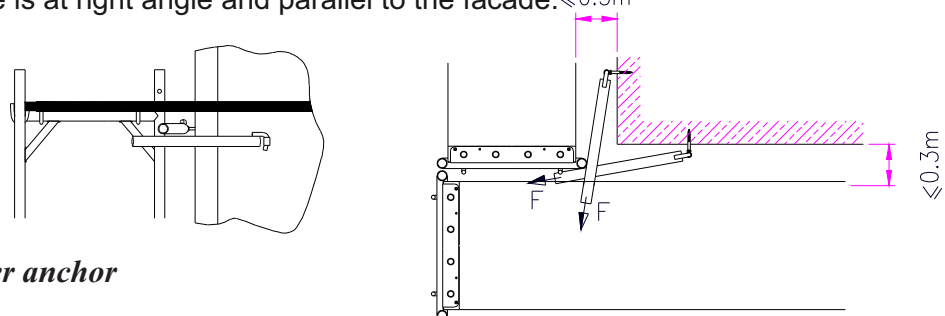

**Fig13: V-anchor**

### Corner anchor (Fig 14)

Corner anchors are fixed only to the inner tubes of the frame.

The anchoring force is at right angle and parallel to the facade. ≤ 0.3m



**Fig 14: Corner anchor**

### 2.4.7 Free-standing scaffolding without anchors:

- Non-anchored scaffolding is free-standing and therefore should be erected safe and stable.
- Maximum standing height should be **6m**
- As support for this structure special supporting tube or tube with couplers should be used.
- Supporting tubes should be fixed to scaffolding with swivel couplers near the point where the frames are connected to each other and anchored in the ground (with dowel, bolt etc).
- Assembly area of scaffolding should be **4 m<sup>2</sup>** outdoors and **2 m<sup>2</sup>** indoors.
- In case the ground does not have sufficient bearing capacity, tubes with couplers for support should be fixed.
- Support should be fixed lengthwise to outer frames and to each second row of frames.

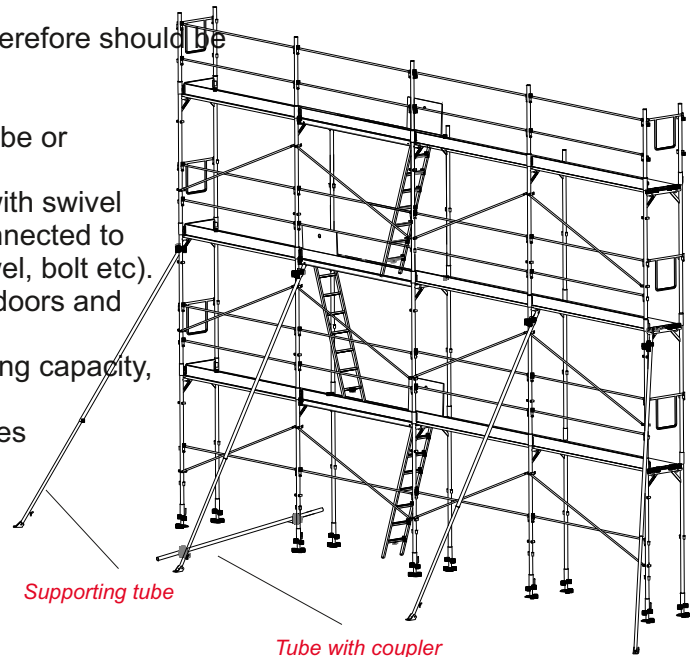

**Fig4: Free-standing scaffolding**

## 2.5 Assembly options and installation of additional accessories

### 2.5.1 Allgemeines

- In this section the various assembly /anchoring grid variations and the assembly of passage frames, bridging beams, enlarging brackets and protective roofs are described.
- By **open facade** (e.g. new building without windows) a wall which is max. 60 % open is meant.
- By **closed facade** (e.g. old building or when windows already installed) openings are not permitted.
- Wind load for the variations described below with safety net is calculated with coefficient  $C_{fx} = 0.60$  and  $C_{fy} = 0.20$ .
- In the tables with various assembly variants working loads are given.

### 2.5.2 Enlarging brackets 0,3m and 0,6m

Brackets are used to enlarge platform surface.  
 For outer side the bracket 0,6 m to be used  
 For inner side to decrease the distance between facade both 0,3 m and 0,6 m can be used.

#### *Bracket 0,3 m (Bracket 0,3m + Quick Bracket 0,3m)*

It can be built in according to assembly variant. It should be fixed to inside tubes of scaffolding frames. Integrated platform protection should be moved over platform surface.

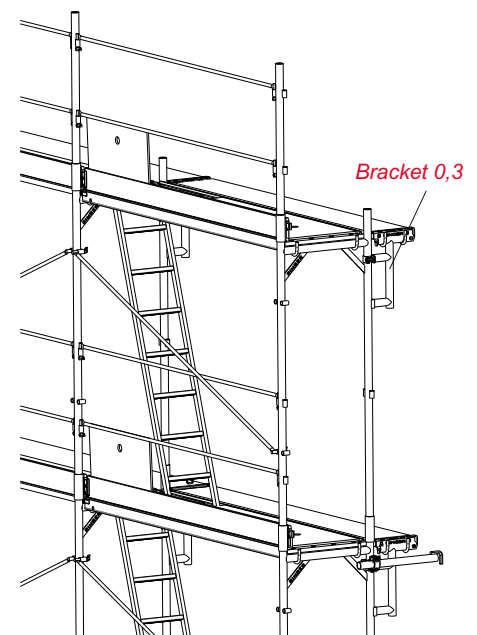
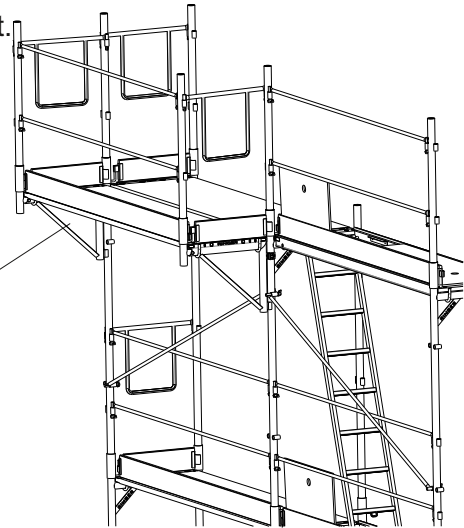

**Fig. 16: Bracket 0,3**

*Bracket 0,6 m*

- Bracket 0,65 m can be used as inside and outside bracket.
- When used as outside bracket, all the knot points at its height should be anchored.
- Platform security should be fixed same way as with frames on the top scaffolding level.

Bracket 0,6



**Fig 17: Bracket 0,6**

2.5.3 Passage Frames

- Passage frames have 1,5 or 2,0 m width and clear height 2.2 m plus height of adjustable base plates. Protective roof is provided by platforms.

*Assembly of passage frames:*

- Passage frames are suitable for storage and transport, i.e. they are demountable. Fix vertical tubes in the traverse beams and secure with captive pins, tighten locking screw.
- Passage frames are assembled and adjusted like standard vertical frames, horizontal braces should be fixed and safeguarded on the lowest level *inside and outside* as shown on Fig 18.
- In base plate area it is recommended to use toe board for border marking for blind and disabled people. For fixing purpose wedge coupler is used.
- Platform (unloaded) that is intended purely to roof over pedestrian area should be fixed with platform security device. This platform surface must not be used as a storage area
- Access to scaffolding is done through horizontally mounted or leaned ladder

Catching area

Cross beam

Vertical tube

Toe board

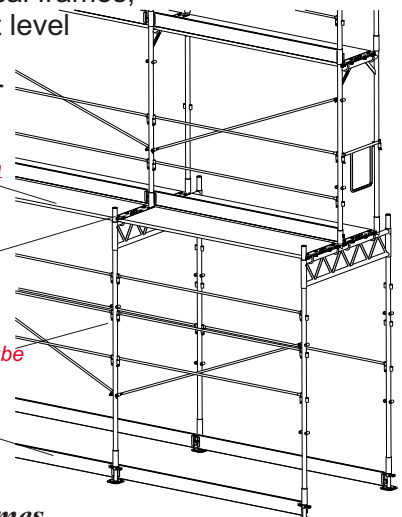

**Attention: only usage of platforms that are permitted for catching area is allowed (see paragraph 1.5)**

**Fig 18: Passage Frames**

2.5.4 Protection Roof

It is used to protect against different objects that can be falling from scaffolding. It consists of two foldable extension brackets in which platforms are fixed.

- Protective roof must not be used as a storage area.
- Entrance to the area is prevented by braces fixed to frames.
- The protective roof may be fixed to the outer side of scaffolding up to 6,0m scaffolding height. At this level every vertical frame must be anchored.

Protection against uplift

Catching area

Protection Fan

Board Bearer

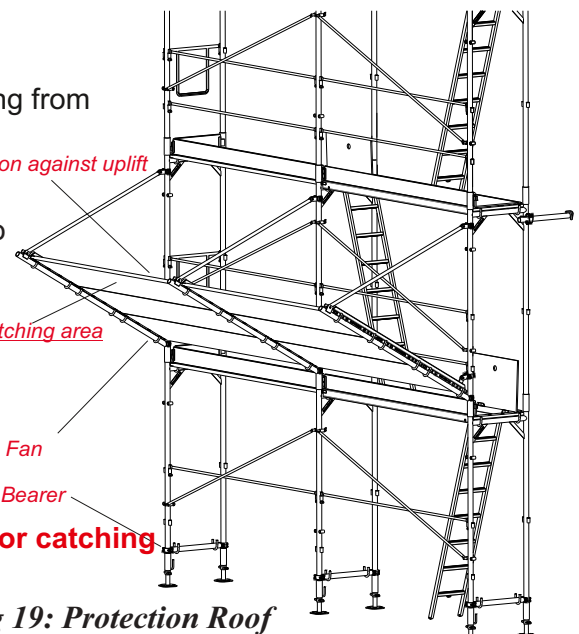

**Attention: only usage of platforms that are permitted for catching area is allowed (see paragraph 1.5)**

**Fig 19: Protection Roof**

### 2.5.5 Catching and roof catching scaffolding:

It is used for personal protection against falling!

- Catching and roof protection scaffolding structure is built with the help of protection post.
- Side protection is ensured by safety grid or protection net according to regulation ÖNORM EN 1263-1 Type „U“ with mesh width 100 mm, which is fixed with belts to top and bottom horizontal braces
- 5 horizontal braces per field should be used
- Top scaffolding frames should be anchored accordingly.

Max. falling height:

- Roof catching scaffolding 1,50 m
- Catching scaffolding 2,00 m

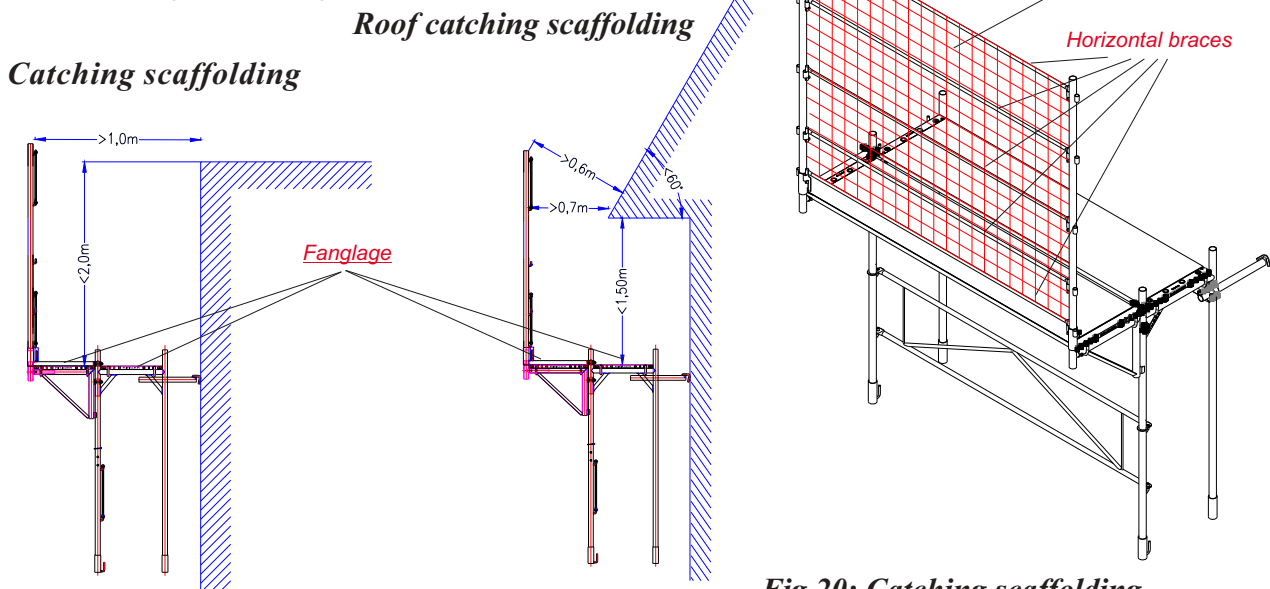

**Fig 20: Catching scaffolding**

**Attention: only usage of platforms that are permitted for catching area is allowed (see paragraph 1.5)**

### 2.5.6 Bridging Beam

Bridging beams are used over large house or shop entrances, or at other traffic routes.

- Bridging beams are fixed with standard couplers as close as possible to the knot point (intersection)
- Frame adaptors should be fixed in the middle to fit platforms and further frames.
- Standard couplers should be fixed inside and outside of the beam as well as on upper and lower bars.

Max. scaffolding height: 24m  
(without additional measures)

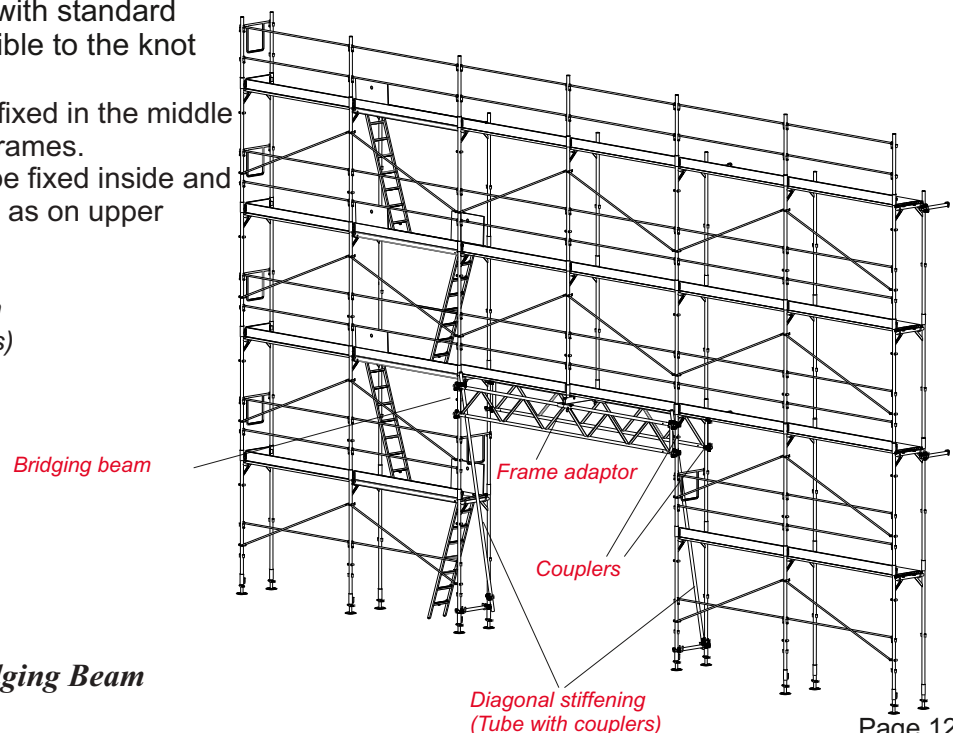
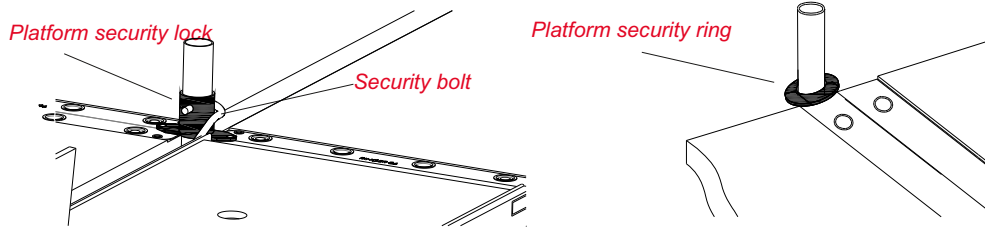

**Fig 21: Bridging Beam**

2.5.7 Protection against platforms uplift:

In assembled scaffolding platforms are protected against uplift by the frames of the next level.

- Platforms on the top level are secured by protection post on the outer side and by platform security ring or lock on the inner side

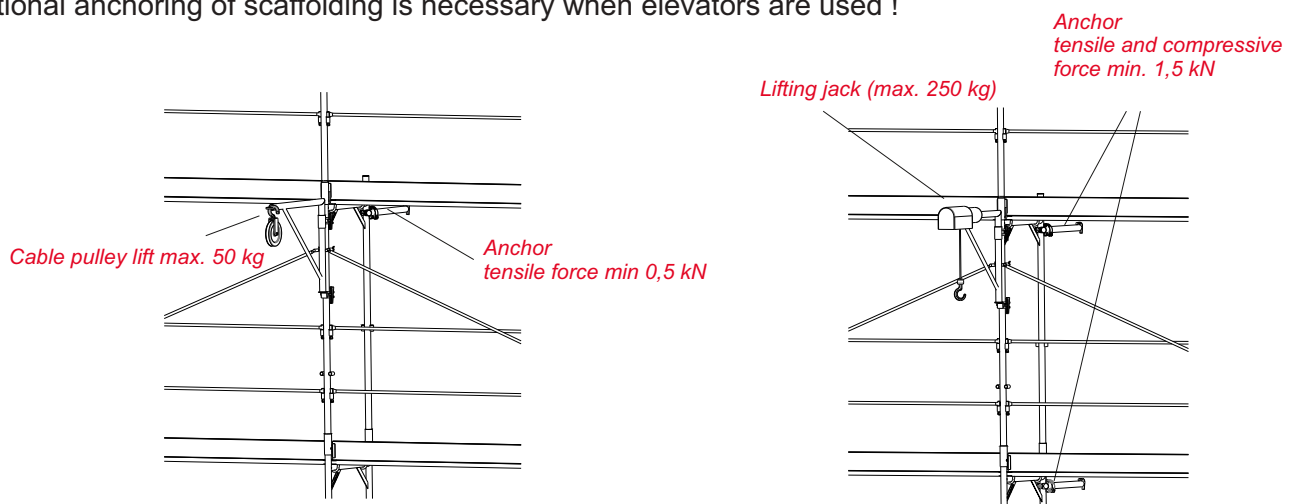

**Fig 22: Protection against uplift**

2.5.8 Elevator for scaffolding parts:

Lifting of material can be done by hand with cable pulley lift or scaffolding lifting jack.

- Additional anchoring of scaffolding is necessary when elevators are used !



**Usage of pulley lift**

**Usage of electrical lifting jack**

2.5.8 Scaffolding net and tarpaulin: Fig 23: Elevators for scaffolding parts

Scaffolding can be covered with net or tarpaulin, in that case additional anchoring is required.

- Net should have wind permeability from C 0,6 (~75g/m<sup>2</sup>).

Net with lower value should be rated as tarpaulin.

- Net and tarpaulin have to be fixed each 50cm to scaffolding frames with expendible fixer or locking bolt

2.5.9 Overlaying scaffolding :

When scaffolding overlay the building not anchored, take care of the following:

- max. overlaying height over last anchor is 4,0 m
- both top frames should be secured with safety bolts or connected with tube and coupler.

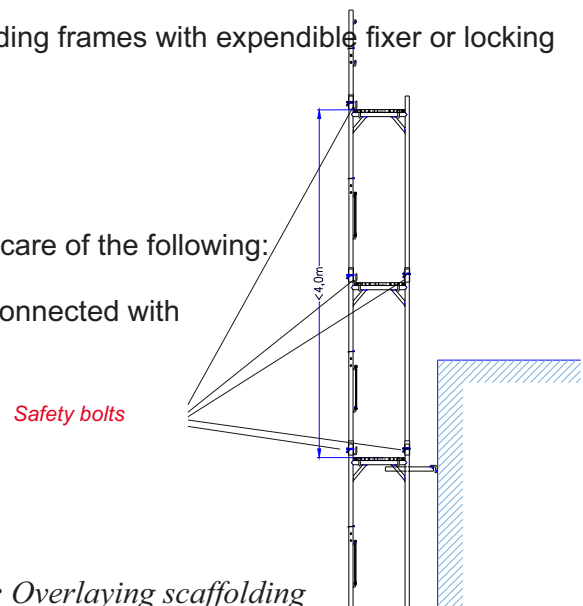

**Fig 24: Overlaying scaffolding**

### 2.5.9 Scaffolding for fixing reinforcement:

Bracing scaffolding is a scaffolding structure that is moved by crane and is used to fix reinforcement in concreted walls.

max. working height: 8 m

max. scaffolding length: scaffolding field

max. load capacity: depending on platform used up to 450 kg/m<sup>2</sup> (scaffolding group 5)

#### Assembly:

During assembly as per below instructions following additional measures are necessary!

- Safeguard frames and protection posts with safety bolts (Fig 25a)
- Safeguard base plate with base plate safety lock (Fig 25b)
- Support scaffolding with min. 2 pcs supporting tubes (Fig 25)

Supporting width: working height 8 m = 2,5 m 4 m = 1,8 m

Support of scaffolding to formwork can be done for example with scaffolding tube and coupler (Fig 25c)

- If the distance from scaffolding to formwork is more than 30 cm brackets or side protection should be used.

#### Moving with crane:

When moving by crane with lifting appliances such as belt or 4-chains device, they should be fixed as shown on Fig 25d. Tilt angle of the belt should not exceed 60°.

- max. net weight of scaffolding: 800 kg

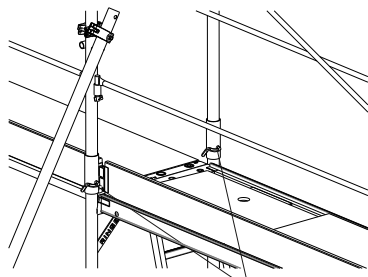

Safety bolts

Fig 25a:

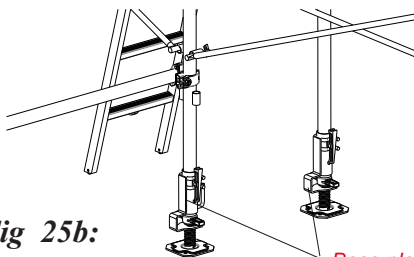
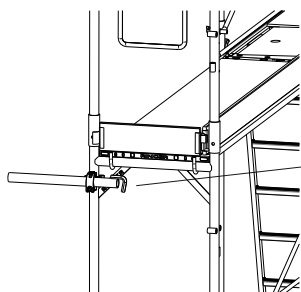

Fig 25b:

Base plate safety lock



Support to formwork

Fig 25c:

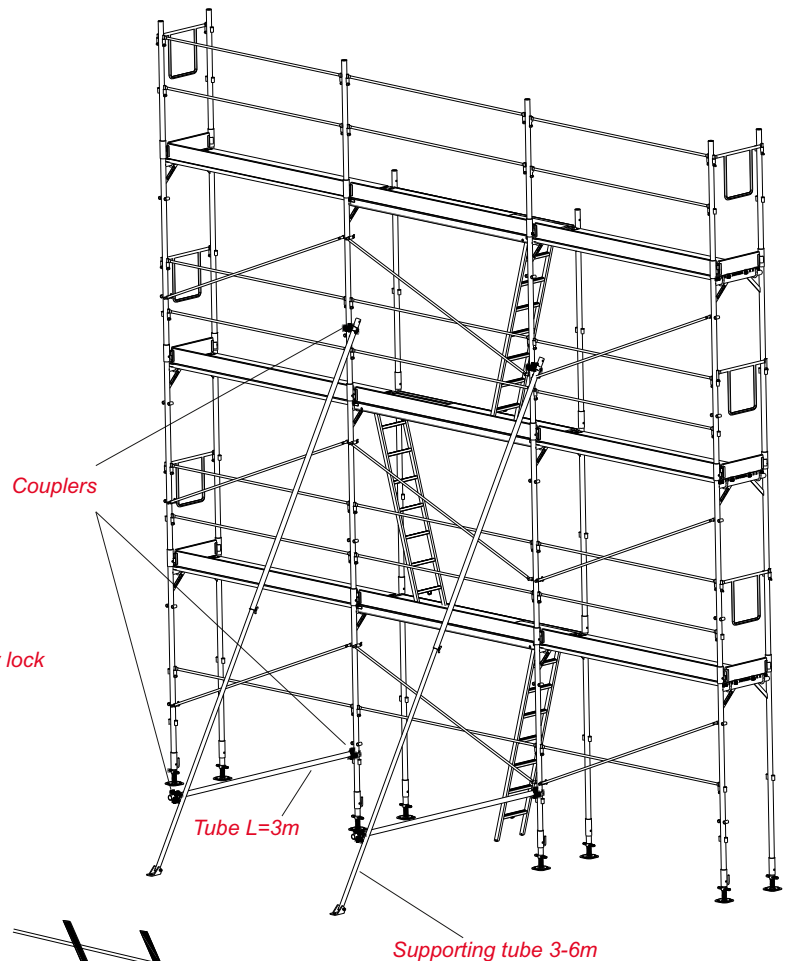

Couplers

Tube L=3m

Supporting tube 3-6m

Fig 25: Scaffolding for reinforcement

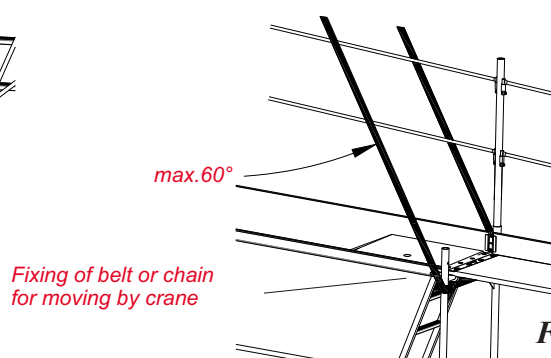

max.60°

Fixing of belt or chain for moving by crane

Fig 25d:

### III) Disassembly of scaffolding

- For scaffolding disassembly, reverse order to what is described above in sections 2.1 to 2.5 should be followed.
- Anchoring should only be removed when above scaffolding levels are completely disassembled.
- Disassembled scaffolding parts should not be stored on the traffic route or thrown down from scaffolding.

### IV) Usage of Ringer Speedy Scaffolding:

- Ringer Speedy Scaffolding should be used in accordance with load bearing class 3 (200 kg/m<sup>2</sup>) as protection and working scaffolding when all the regulations of the User Manual are strictly followed.  
(Higher load capacity class is possible with suitable platforms for certain assembly options. Please contact company Ringer)
- Standard assembly is approved with dynamic pressure  $q=1,1 \text{ kN/m}^2$  at height  $H=24 \text{ m}$ . This corresponds to wind speed  $\sim v=42 \text{ m/s}$  or  $v=151 \text{ km/h}$ . In case of windstorm danger when the above values are exceeded, additional procedures are necessary: *additional anchoring, removing of net or tarpaulin or disassembly!*
- The user of Speedy Scaffolding should recheck the acceptability of assembly variant and to control safety function according to the required task.
- Additional changes for assembly/reassembly/disassembly should be done only by professionally trained personnel
- Control for operation safety should be repeated in such cases as long break in usage, accidents or unusual natural phenomenon. The results of this control should be recorded!
- The approval of scaffolding and proper implementation should be recorded!  
(Scaffolding acceptance report)
- It is forbidden to jump or to through anything onto scaffolding field
- It is forbidden to use for storage of material or construction equipment scaffolding surface that is used as protection roof or catching scaffolding.
- Take care of national norms and regulations!

### V) Assembly options:

Paragraph	Calculated assembly variants	Anchor pattern	Page
5.1.1	Basic variant for open and closed facade	8 m staggered	16
5.1.2	Bracket variant for open and closed facade	8 m staggered	17
5.2.1	Basic variant with net for closed facade	8 m staggered	18
5.2.2	Bracket variant with net for closed facade	8 m staggered	19
5.2.3	Basic and bracket variant with net for open facade	4m	20
5.3	Scaffolding with tarpaulin for open and closed facade	2m	21
5.4	Variant with bridging beam and protection roof	acc. assembly variant	22
5.5	Variant with separate ladder ascent	acc. assembly variant	23
5,6	Variant with passage frames	acc. assembly variant	24

# BASIC VARIANT

-without safety net/tarpaulin  
-with/without roof protection

Anchor grid 8m staggered

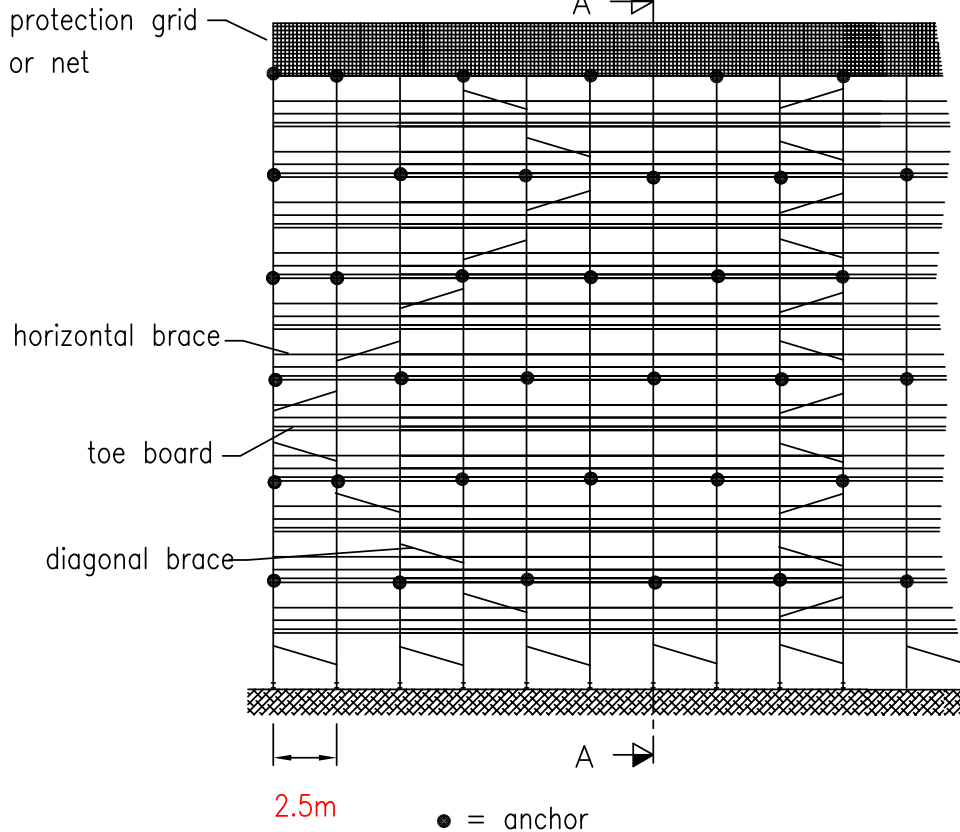

Cross cut A-A

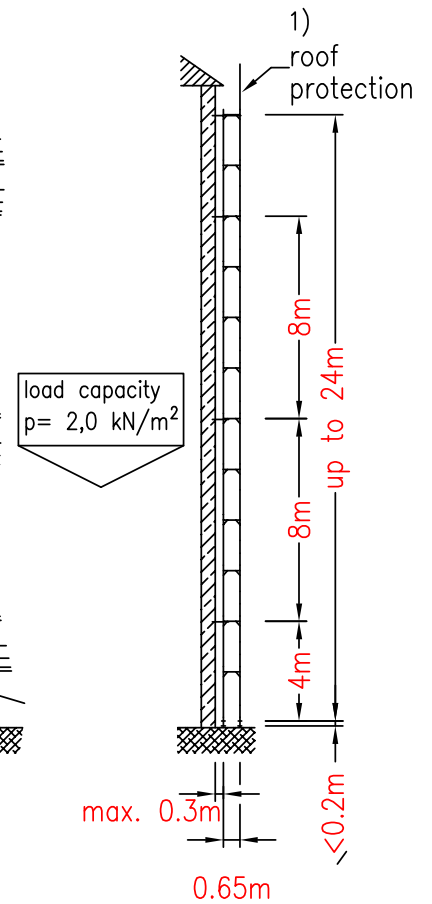

Facade		open	closed
Base plate load	inside:	10,1 kN	9,9 kN
	outside:	12,3 kN	11,8 kN
Anchor forces	perpendicular:	3,1 kN	1,3 kN
	parallel:	anchor: 4,3 kN	4,3 kN
	V-anchor: max. inclined load:	3,5 kN	3,0 kN

## 5.1.1 BRACKET VARIANT

-without safety net/tarpaulin  
-with/without roof protection

Anchor grid 8m staggered

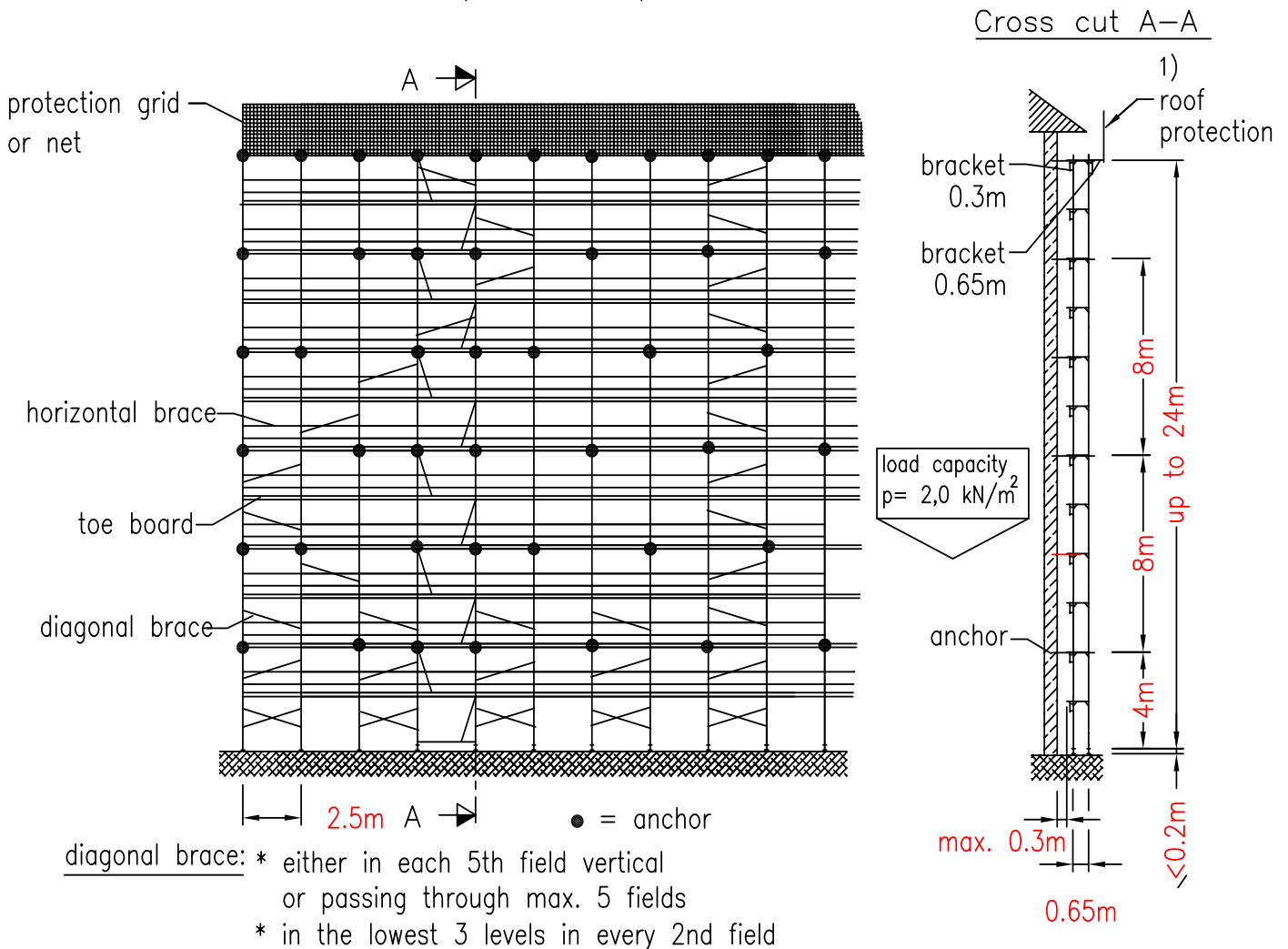

Facade		open	closed
Base plate load	inside:	14,8 kN	14,6 kN
	outside:	15,9 kN	15,4 kN
Anchor forces	perpendicular:	3,3 kN	1,4 kN
	parallel:	anchor: 1,9 kN	1,9 kN
	V-anchor: max. inclined load:	3,5 kN	3,0 kN

## 5.1.2 VARIANT WITH BRACKETS

Anchor grid 8m staggered

-for closed facade  
-with/without roof protection

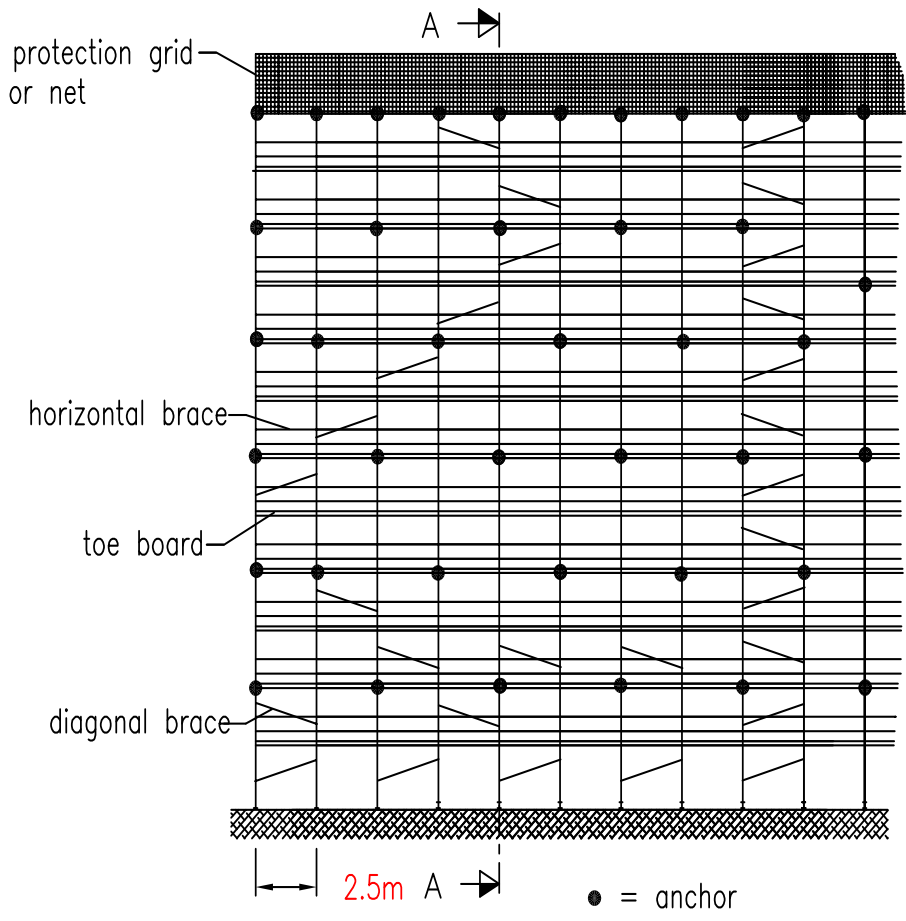

diagonal brace: \* either in each 5th field vertical  
or passing through max. 5 fields

Cross cut A-A

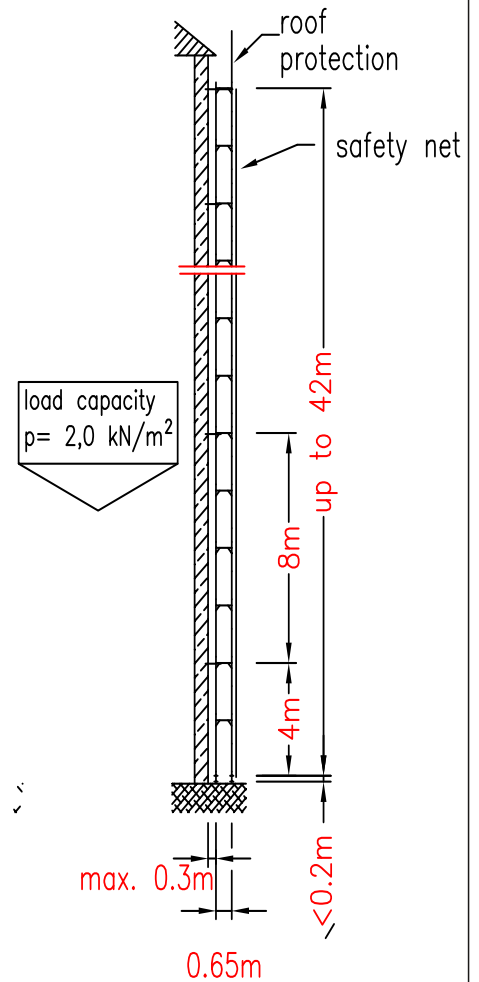

Facade		closed
Base plate load	inside:	10,1 kN
	outside:	14,8 kN
Anchor forces	perpendicular:	2,4 kN
	parallel:	anchor: 3,6 kN

## 5.2.1 BASIC VARIANT WITH NET

Anchor grid 8m staggered

- for closed facade
- with/without roof protection

Cross cut A-A

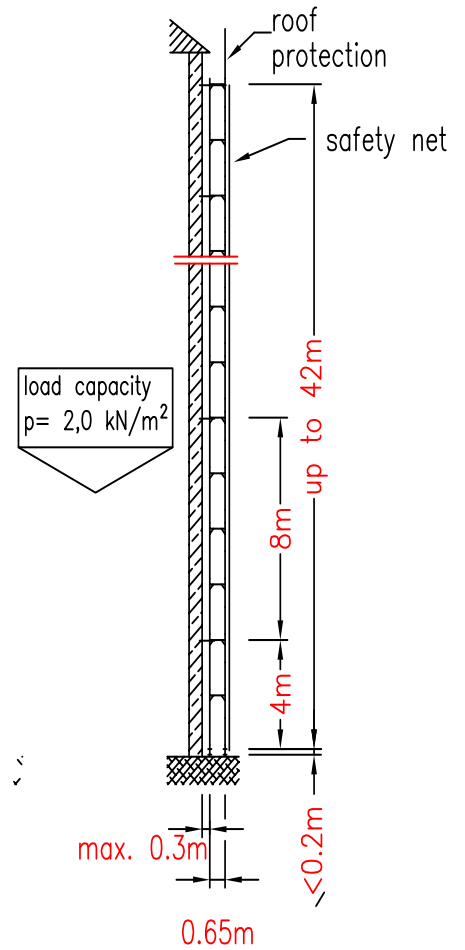
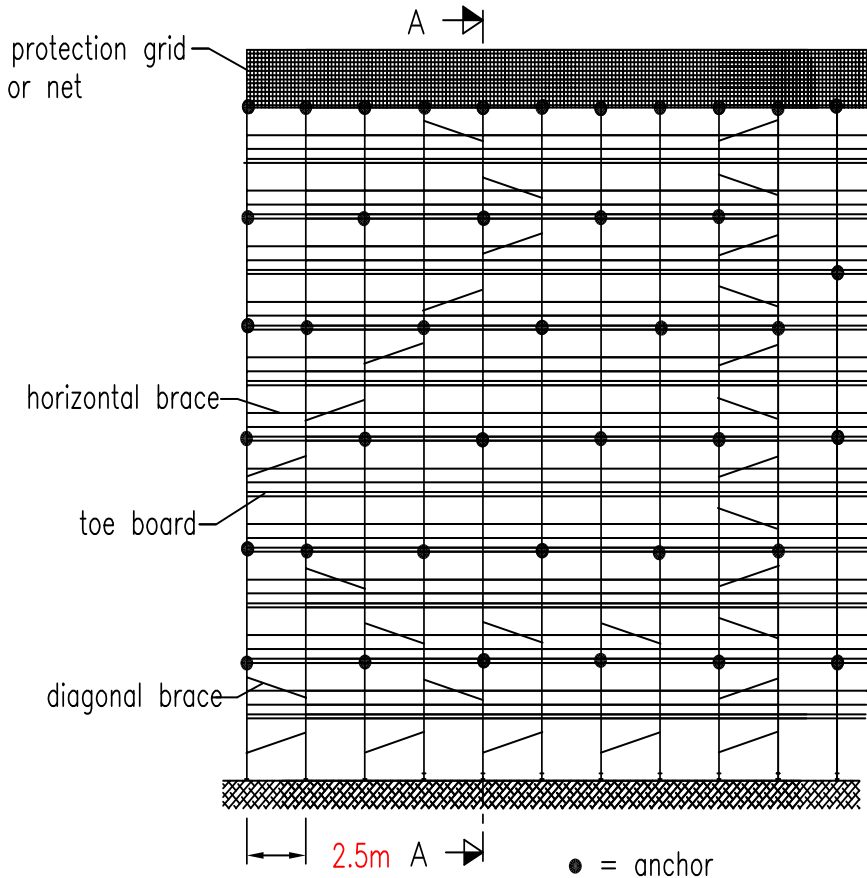

diagonal brace: \* either in each 5th field vertical or passing through max. 5 fields

Facade		closed
Base plate load	inside:	10,1 kN
	outside:	14,8 kN
Anchor forces	perpendicular:	2,4 kN
	parallel:	anchor: 3,6 kN

## 5.2.3 BASIC AND BRACKET VARIANT WITH NET

- for open facade
- with/without roof protection

Anchor grid 4m

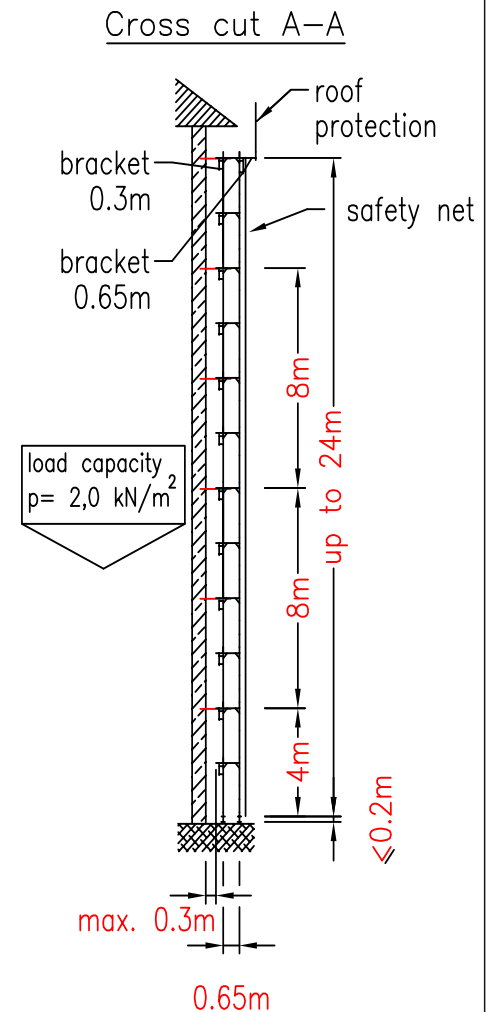
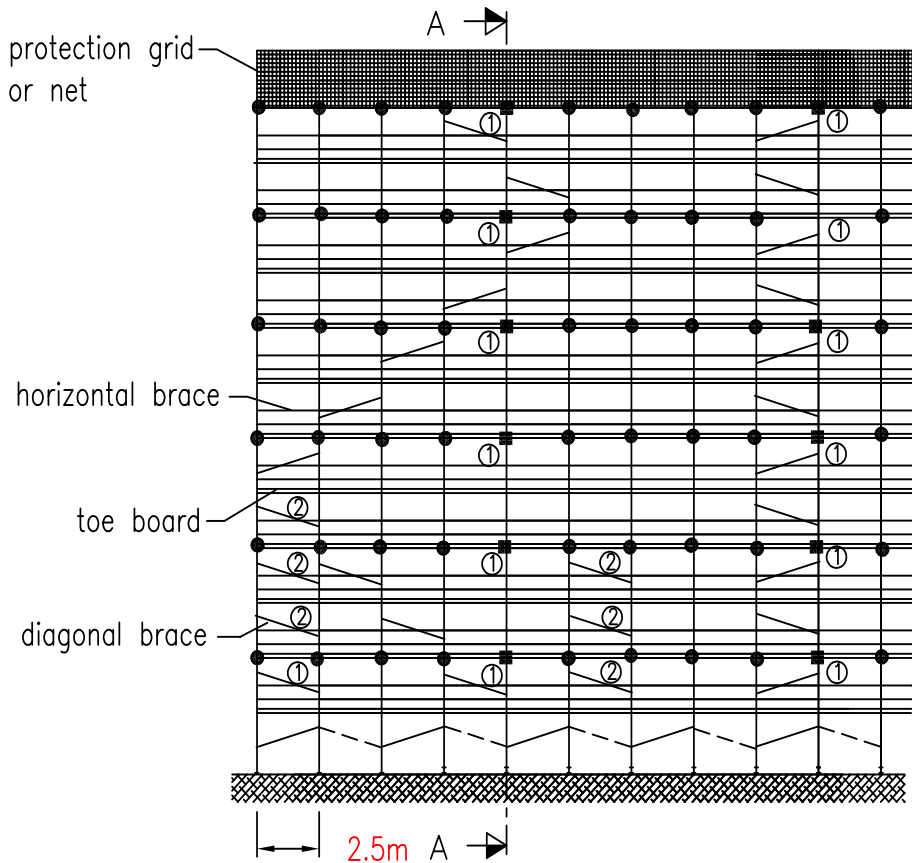

diagonal brace: \* either in each 5th field vertical or passing through max. 5 fields

\* Basic variant: in the lowest level in every 2nd field

\* Bracket variant: in the lowest level in every field (shown in dashed lines)

Anchor: ● = anchor

■ V-anchor -> two v-shaped anchors, fixed to inner tube.

one piece every 5th field in each anchor level

- ① the V-anchors can be replaced by short ones in the basic variant
- ② if only brackets 0,3m used inside, these diagonal braces can be omitted

Facade		Basic variant open	Bracket variant open
Base plate load	inside:	8,1 kN	12,8 kN
	outside:	10,6 kN	14,2 kN
Anchor forces	perpendicular:	3,8 kN	3,8 kN
	parallel:	anchor: 3,7 kN	0,5 kN
	V-anchor: max. inclined load:	5,4 kN	5,4 kN

## 5.3 VARIANT WITH TARPAULIN

- for open and closed facade
- with/without brackets
- with/without roof protection

Anchor grid 2m

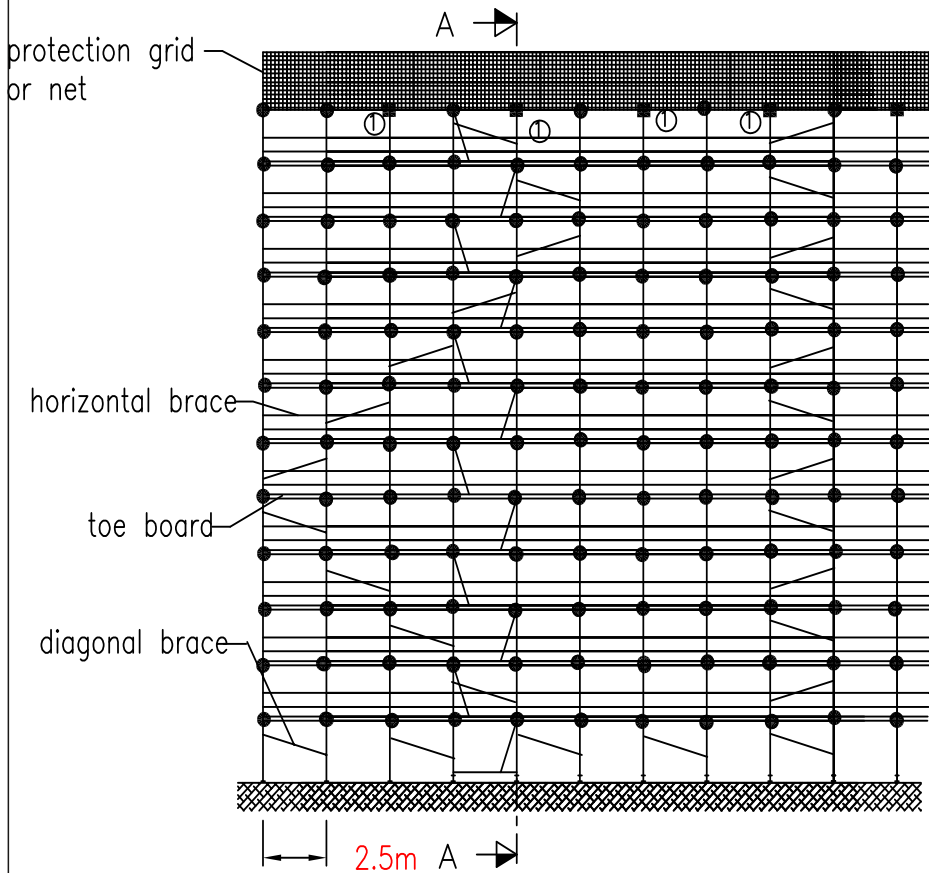

Cross cut A-A

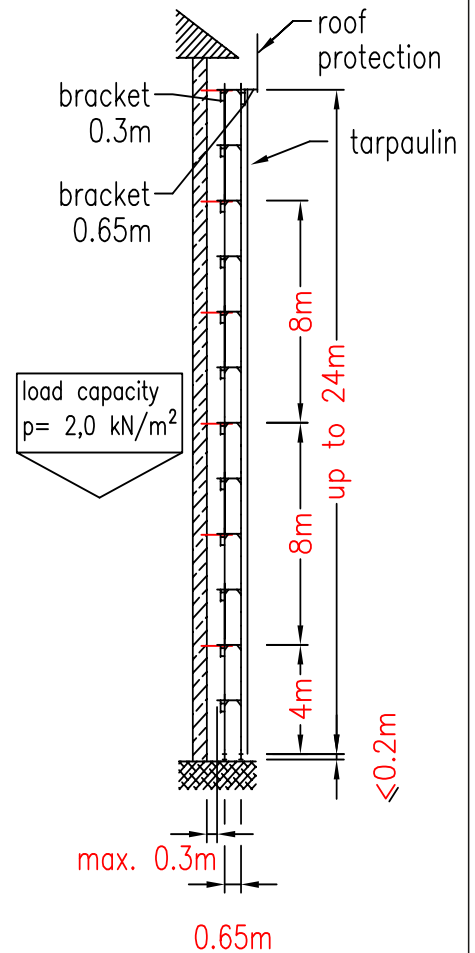

diagonal brace: \* either in each 5th field vertical  
or passing through max. 5 fields

\* in the lowest level in every 2nd field

Anchor: ● = anchor

■ V-anchor → two v-shaped anchors,  
fised to inner tube.

one piece every 5th field in each anchor level

① the V-anchors can be replaced by  
short ones in the basic variant

Facade		open	closed
Base plate load	inside:	11,7 kN	11,3 kN
	outside:	12,4 kN	12,4 kN
Anchor forces	perpendicular:	compression 4,9 kN tension 4,4 kN	compression 3,8 kN tension 2,7 kN
	parallel: anchor:	1,8 kN	1,8 kN
	V-anchor: max. inclined load:	4,2 kN	3,6 kN

## 5.4 VARIANT WITH BRIDGING BEAM

- for basic or bracket variant
- open and closed facades
- without safety net/tarpaulin
- with/without roof protection

Anchor grid according to assembly variant

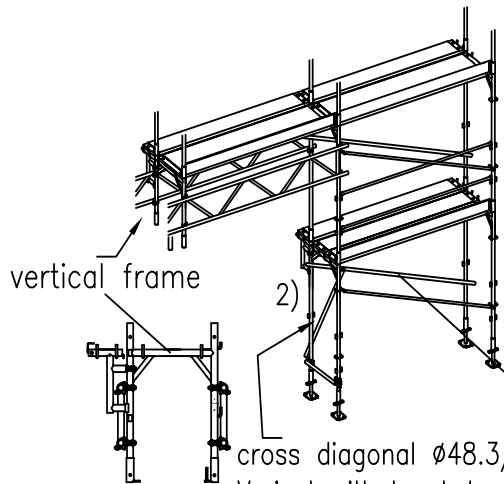
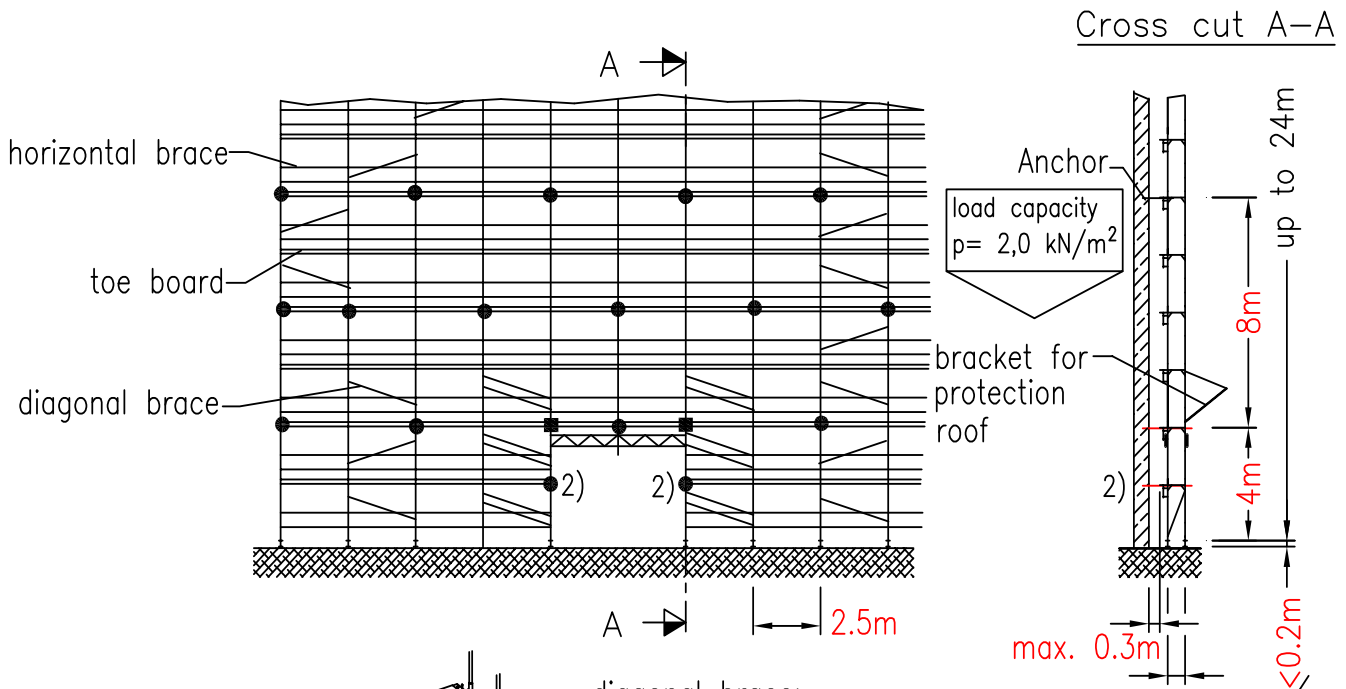

diagonal brace:

- \* either in each 5th field vertical or passing through max. 5 fields
- \* in the lowest 3 levels in every 2nd field
- \* in fields next to the bridging beam
- \* in fields next to the bridging beam inside either with Uni-diagonal brace or tube with coupler

Variant with brackets or protection roof

Anchor: ● = anchor

- V-anchor → two v-shaped anchors, attached to the inner tube. once every 5th field in each anchor level

		Basic variant (without brackets)	Bracket variant with protection roof
Base plate load	inside:	19,7 kN	16,1 kN
	outside:	18,0 kN	20,2 kN

- Anchor grid and forces, see corresponding assembly variant!

## 5.5 VARIANT WITH SEPARATE LADDER ASCENT

Anchor grid according to assembly variant

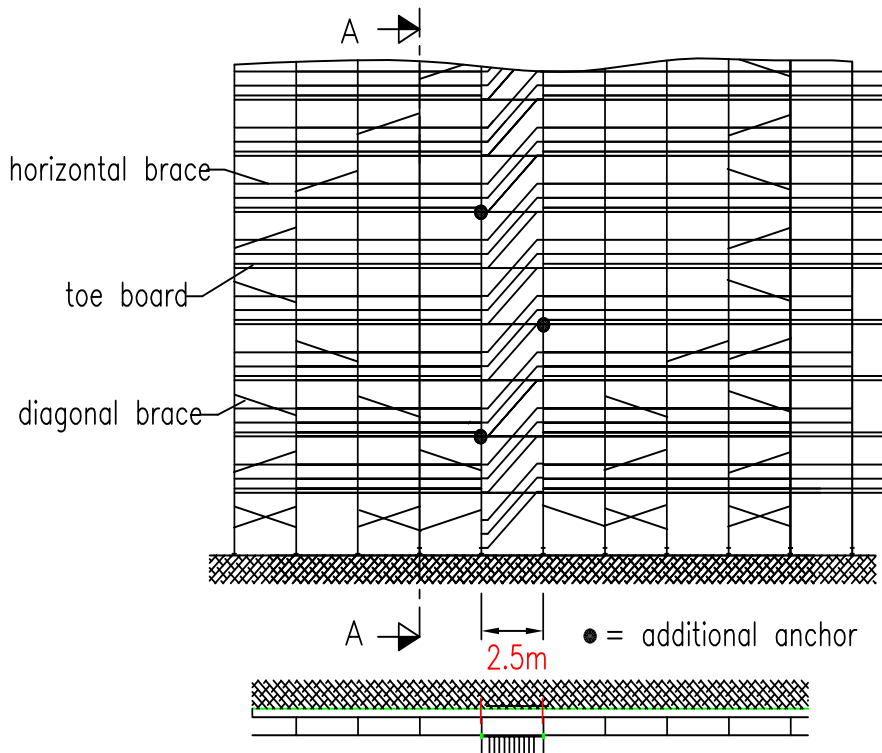

Cross cut A-A

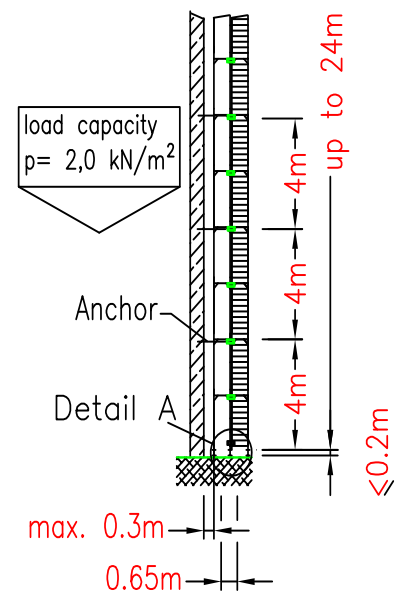

Detail A

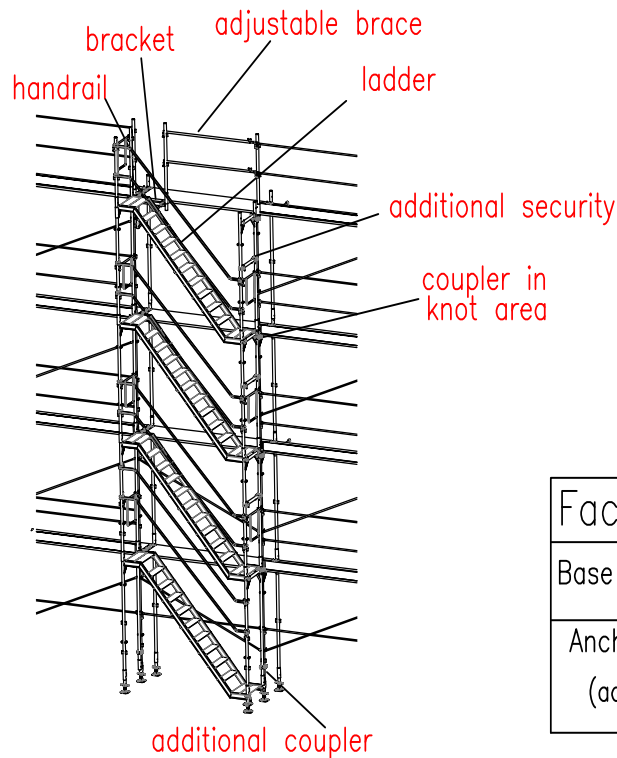
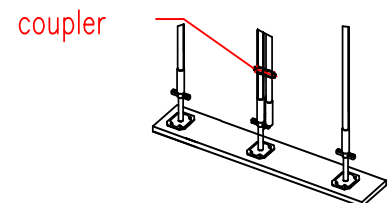

Facade		open
Base plate load	inside additional:	5,0 kN
	outside:	9,2 kN
Anchor forces (additional)	perpendicular:	1,0 kN
	parallel:	2,0 kN

## 5.6 PASSAGE FRAMES WITH AND WITHOUT BRACKETS

- for open and closed facade
- without safety net/tarpaulin
- with/without protection roof
- with bracket 0.3m inside or with/without bracket 0.65m outside

Anchor grid accoring to assembly variant

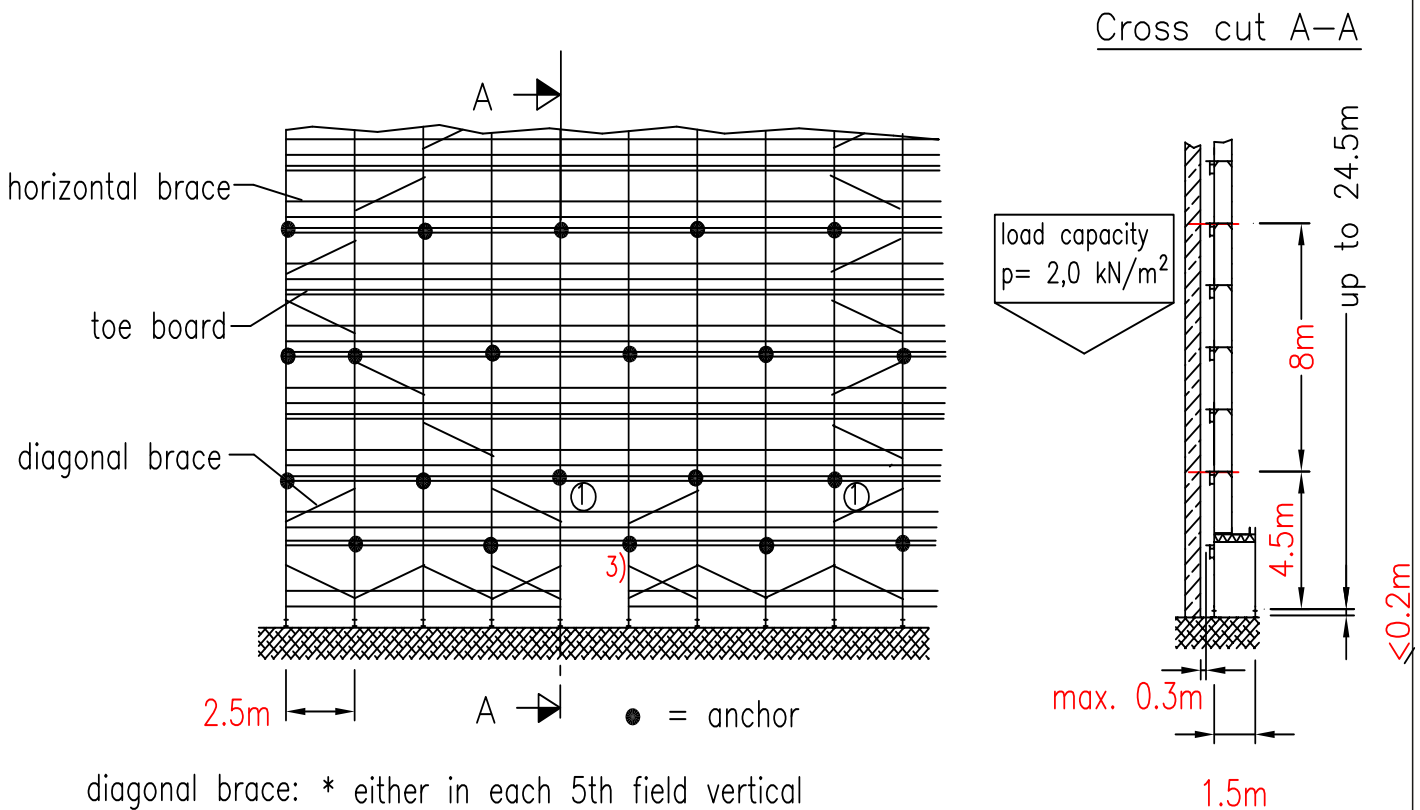

diagonal brace: \* either in each 5th field vertical or passing through max. 5 fields  
\* in the lowest floor (passage frame) in each field outside

Facade		open	closed	
Base plate load	inside:	19,7 kN	19,7 kN	
	outside:	7,1 kN	7,1 kN	
Anchor forces	perpendicular:	Anchor grid and forces, see corresponding assembly variant!		
	parallel:			Anchor:
	V-Anchor:			max. inclined load:

3) To allow a free passage to the ladder field and house entrance, the braces can be omitted in every 5th field. In the neighboring fields 2 extra diagonal braces are to be fixed.

# Speedy Scaffolding with Platforms / System Parts

## Frames for Speedy Scaffolding

Art. Nr.	Item	Weight	Unit
111 0001	Frame 0,65 x 2 m for Speedy Scaffolding	16,50	pc
111V0001	Frame 0,65 x 2 m for Speedy Scaffolding galvanized	17,50	pc

## Half-Frames for Speedy Scaffolding

Art. Nr.	Item	Weight	Unit
111 0029	Half-Frame 0,65 x 1 m for Speedy Scaffolding	11,50	pc
111V0029	Half-Frame 0,65 x 1 m for Speedy Scaffolding galvanized	11,30	pc

## Special Frames for Speedy Scaffolding

Art. Nr.	Item	Weight	Unit
111V00011	Cornice Frame 0,65 x 2 m for Speedy Scaffolding galvanized	25,00	pc

## Braces for Speedy Scaffolding

Art. Nr.	Item	Weight	Unit
111 0003	Diagonal Brace 2,5 m	4,20	pc
131 0003	Diagonal Brace 3 m	5,00	pc
111V0003	Diagonal Brace 2,5 m galvanized	4,50	pc
111V0031	Diagonal Brace 2 m galvanized	3,50	pc
111V0032	Diagonal Brace 1,5 m galvanized	3,10	pc
111V0033	Diagonal Brace 1,25 m galvanized	2,90	pc
111 0004	Horizontal Brace 2,5 m	4,00	pc
131 0004	Horizontal Brace 3 m	4,80	pc
111V0004	Horizontal Brace 2,5 m galvanized	4,30	pc
111V0041	Horizontal Brace 2 m galvanized	3,60	pc
111V0042	Horizontal Brace 1,5 m galvanized	2,60	pc
111V0043	Horizontal Brace 1,25 m galvanized	2,30	pc
112 0012	End Guardrail 0,65 m for Speedy Scaffolding	2,50	pc
112V0012	End Guardrail 0,65 m for Speedy Scaffolding galvanized	3,00	pc
113V0011	Adjustable Guardrail for Speedy Scaffolding galvanized	6,00	pc

## Protection Post for Speedy Scaffolding

Art. Nr.	Item	Weight	Unit
111 0006	Guardrail Post for Speedy Scaffolding	3,80	pc
111V0006	Guardrail Post for Speedy Scaffolding galvanized	4,00	pc

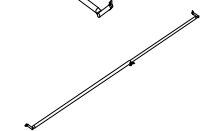
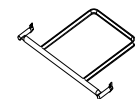
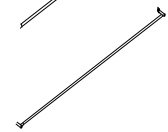
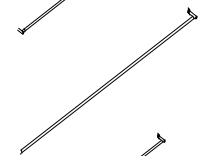
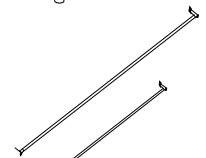
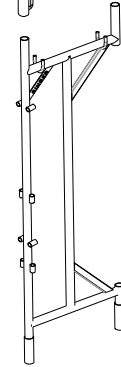
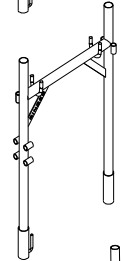
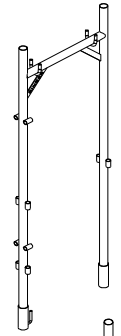

# WORKING PLATFORMS

## Platforms from Solid Wood width 60 cm

Art. Nr.	Item	Weight	Unit
111S2	Platform "S" 0,6 x 2,5 m, (grey) Scaffolding group 3 acc. EN12810 (also for roof catching)	26,00	pc
111 2	Platform 0,6 x 2,5 m (red)	26,00	pc
111 16	Platform 0,6 x 2 m (red)	22,50	pc
111 17	Platform 0,6 x 1,50 m (red)	16,50	pc
111 13	Platform 0,6 x 1,25 m (red)	13,00	pc
111 05	Platform 0,6 x 0,72 m (red)	8,00	pc
111 15	Platform 0,6 x 0,72 m (red)	7,00	pc
111 3	Platform 0,6 x 3,0 m (red)	36,00	pc
111 21	Compensation Board 0,55 x 2,5 m (red)	24,00	pc
290V702	Platform Security Ring galvanized	0,12	pc

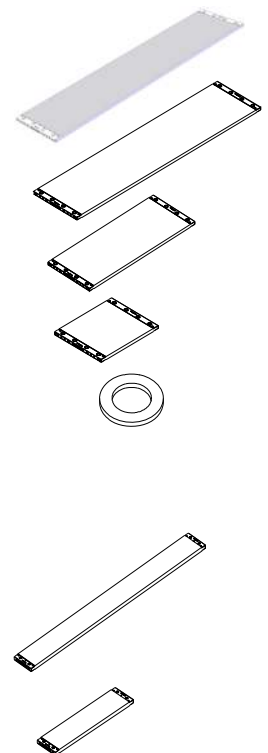

## Platforms Solid Wood width 30 cm

Art. Nr.	Item	Weight	Unit
100 02	Platform 0,3 x 2,5 m	14,40	pc
100 05	Platform 0,3 x 2,0 m	11,50	pc
100 06	Platform 0,3 x 1,5 m	8,50	pc
100 03	Platform 0,3 x 1,25 m	7,50	pc
100 04	Platform 0,3 x 0,72 m	4,30	pc
100 01	Platform 0,3 x 3,0 m	18,00	pc

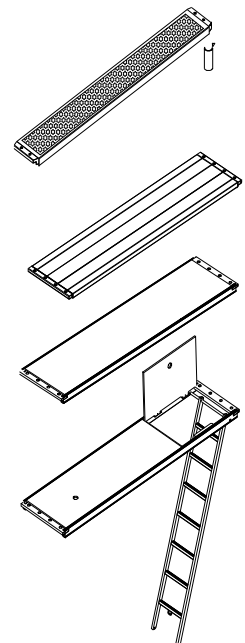

## Steel Platforms

Art. Nr.	Item	Weight	Unit
111V25	Steel Platform 0,315 x 2,5 m galvanized	16,50	pc

## Toe-Boards Solid Wood

Art. Nr.	Item	Weight	Unit
113 0014	Toe-Board 2,5 m x 2 cm (height 15 cm)	3,70	pc
113 143	Toe-Board 2,0 m x 2 cm (height 15 cm)	3,10	pc
113 144	Toe-Board 1,5 m x 2 cm (height 15 cm)	2,50	pc
113 145	Toe-Board 1,25 m x 2 cm (height 15 cm)	2,10	pc
113 142	Toe-Board 1,0 m x 2 cm (height 15 cm)	1,50	pc
113 148	Toe-Board 0,72 m x 2 cm (height 15 cm)	1,40	pc
113 141	Toe-Board 0,65 m x 2 cm (height 15 cm)	1,30	pc
113 0012	Toe-Board 3,0 m x 3 cm (height 15 cm)	6,20	pc

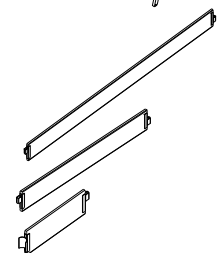

## ACCESSORIES

### Base Plates; Wheels; Anchoring

#### Base Plates

Art. Nr.	Item	Weight	Unit
112 0009	Base Plate	0,70	pc
112V0009	Base Plate galvanized	0,90	pc
132V0005	Adjustable Base Plate 25/40 cm galvanized	3,50	pc
132V0018	Adjustable Base Plate 45/60 galvanized	4,10	pc
132V0006	Adjustable Base Plate 60/80 cm galvanized	5,00	pc
132V0007	Adjustable Base Plate 60/80 cm pivoting galvanized	5,50	pc
112V0016	Adjustable Base Plate 60 cm for Adjustable Leg galvanized	3,60	pc
81008	Base Plate Protection galvanized	1,50	pc

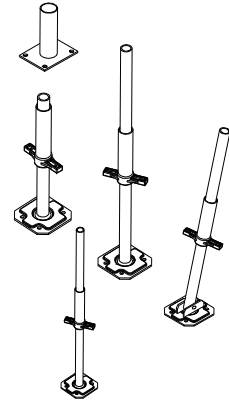

#### Wheels for Scaffolding

Art. Nr.	Item	Weight	Unit
133 0013	Wheel with Brake for 205 kg with Base Plate	4,20	pc
133 0012	Wheel without Brake for 205 kg with Base Plate	4,10	pc
133 0011	Wheel with Brake for 205 kg without Base Plate	3,20	pc
133 0010	Wheel without Brake for 205 kg without Base Plate	3,10	pc
133 0020	Wheel with Brake for 400 kg with Base Plate	4,20	pc
112 0090	Base Plate with Fall Protection	1,00	pc

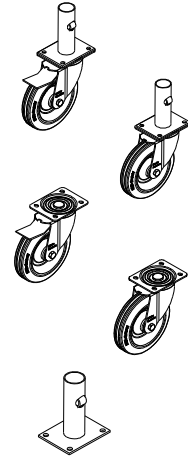

#### Wall Anchoring

Art. Nr.	Item	Weight	Unit
112 0008	Anchor 0,6 m (wall anchoring)	1,80	pc
112V0008	Anchor 0,6 m galvanized (wall anchoring)	2,40	pc
290 0048	Anchor 1 m (wall anchoring)	3,20	pc
290V0048	Anchor 1 m galvanized (wall anchoring)	3,80	pc
112V0001	Anchor 1,5 m galvanized (wall anchoring)	5,30	pc
112V2	Anchor 2 m galvanized (wall anchoring)	7,30	pc
290V0069	Screw with safety head 18 cm galvanized	0,22	pc
290V0070	Screw with safety head 25 cm galvanized	0,25	pc
290V0071	Screw with safety head 30 cm galvanized	0,30	pc
290V0072	Screw with safety head 40 cm galvanized	0,34	pc
290V0073	Screw with safety head 50 cm galvanized	0,60	pc
290V636	Anchor Screw GS 27 cm galvanized	0,30	pc
290V635	Anchor Screw GS 35 cm galvanized	0,37	pc
290 0011	Fischer Dowel S16	0,10	10pc

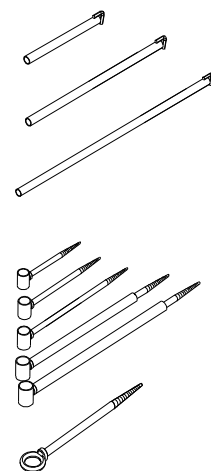

#### Supporting Tubes

Art. Nr.	Item	Weight	Unit
113 00161	Supporting Tube 3 - 6 m with Base Plate	16,50	pc
113V00161	Supporting Tube 3 - 6 m with Base Plate galvanized	17,00	pc

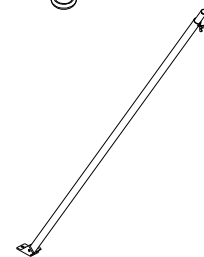

# Height Adjustment, Brackets and Bridging

## Frames for Height Adjustment

Art. Nr.	Item	Weight	Unit
112 0018	Adjustable Frame 0,65 x 2 m (incl. tubes)	21,00	pc
112V0018	Adjustable Frame 0,65 x 2 m galvanized (incl. tubes)	22,00	pc
112 0020	Adjustable frame without tubes	9,20	pc
112V0020	Adjustable frame without tubes galvanized	10,00	pc
290 0052	Tube for Adjustable Frame $\varnothing$ 48,3mm	6,00	pc
290V0052	Tube for Adjustable Frame galvanized $\varnothing$ 48,3mm	6,80	pc
112 0017	Adjustable Leg 0 - 1 m with bolts	3,30	pc
112V0017	Adjustable Leg 0 - 1 m with bolts galvanized	3,50	pc
112V0019	Safety Bolt $\varnothing$ 12 galvanized	0,25	pc
132 0015	Adjustable Leg for 2 m with tube	9,50	pc
113 28	Board Bearer 0,65 m	4,00	pc
113V28	Board Bearer 0,65 m galvanized	3,50	pc

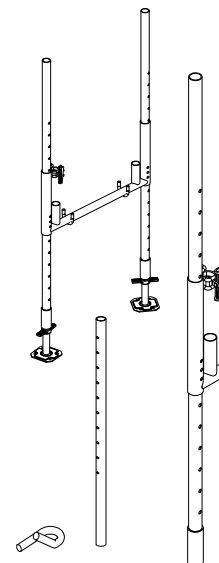

## Brackets

Art. Nr.	Item	Weight	Unit
112 0021	Bracket 0,6 m with Screw Coupler	5,80	pc
112V0021	Bracket 0,6 m with Screw Coupler galvanized	6,20	pc
112 0006	Angle for Bracket with Screw	1,20	pc
112V0006	Angle for Bracket with Screw galvanized	1,40	pc
112 0026	Bracket 0,6 m with welded Angle	5,60	pc
112V0026	Bracket 0,6 m with welded Angle galvanized	5,60	pc
12V22	Enlarging Bracket 0,65 m galvanized	8,50	pc
12V23	Bracket 0,6 m for Inside and Outside Corner galvanized	8,90	pc
112 0025	Bracket 1,2 m	20,50	pc
112 0023	Bracket 0,9 m	19,50	pc
112 0022	Bracket 0,9 m for mounting to walls	17,00	pc
121V0008	Bracket 0,3 m with Screw Coupler and Platform security galvanized	5,10	pc
121V0009	Quick Bracket 0,3 m with Screw Coupler and Platform security galvanized	3,00	pc

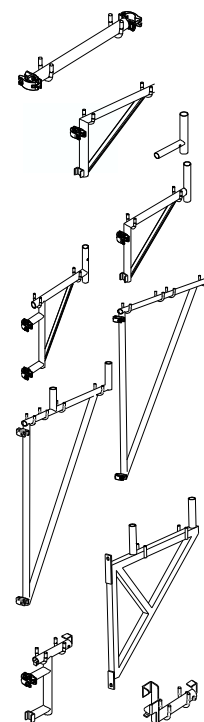

## Gibbet

Art. Nr.	Item	Weight	Unit
113V0020	Gibbet swivel galvanized	7,70	pc

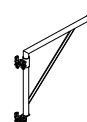

## Bridging Beam

Art. Nr.	Item	Weight	Unit
113 55	Bridging Beam 3,10 m ALU	11,00	pc
113 53	Bridging Beam 5,20 m ALU	19,60	pc
113 54	Bridging Beam 8,10 m ALU	31,00	pc
113V0	Tube Connector $\varnothing$ 38 x 450 mm for Bridging Beam with Screws galvanized	2,00	pc
113V8	Frame Adapter 0,65 for Bridging Beam galvanized	9,00	pc
113V9	Bracket 0,3 m for Bridging Beam galvanized	1,50	pc

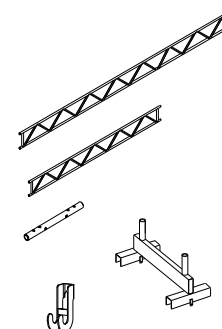

Art. Nr.	Item	Weight	Unit
113 27	Passage Frame T 150 for Schnellbau (with tubes)	37,00	pc
113V27	Passage Frame T 150 for Schnellbau galvanized (with tubes)	39,00	pc
113 30	Passage Frame T 155 for Schnellbau (with tubes)	36,50	pc
113V30	Passage Frame T 155 for Schnellbau galvanized (with tubes)	36,50	pc
113 29	Passage Frame T 200 for Schnellbau (with tubes)	50,00	pc
113V29	Passage Frame T 200 for Schnellbau galvanized (with tubes)	53,00	pc
113 272	Post for Passage Frame for Schnellbau	10,00	pc
113V272	Post for Passage Frame for Schnellbau galvanized	10,50	pc
113 271	Bridge for Passage Frame T 150	17,00	pc
113V271	Bridge for Passage Frame T 150 galvanized	18,00	pc
113 281	Bridge for Passage Frame T 155	16,50	pc
113V281	Bridge for Passage Frame T 155 galvanized	17,50	pc
113 291	Bridge for Passage Frame T 200	23,00	pc
113V291	Bridge for Passage Frame T 200 galvanized	24,50	pc

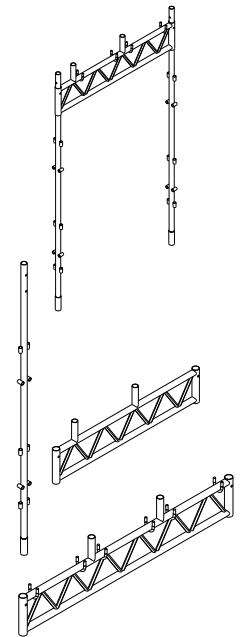

## SCAFFOLDING ASCENT FOR SYSTEM RINGER

### Stairs for Scaffolding with 2,5 m Distance between Frames

Art. Nr.	Item	Weight	Unit
113V0025	ScaffoldingLadder 2,5m galvanized	37,50	pc
80082	Alu Ladder 0,6 m width	27,00	pc
113V0026	Handrail 2,5 m galvanized	7,00	pc
800812	Inside Guardrail for Ladder 0,6 x 1,4 m galvanized	11,50	pc

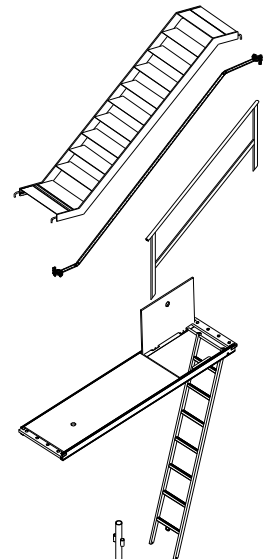

### Arbeitsbühne mit Klappe und integrierter Leiter

Art. Nr.	Item	Weight	Unit
120 2	Alu Platform 2,5 m with Flap and integrated Ladder	24,00	pc
120 4	Alu Platform 2,5 m (all-over aluminium) with Flap and integrated Ladder	22,50	pc

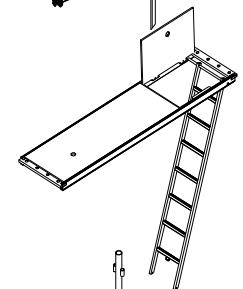

## PROTECTION SCAFFOLDING AND SAFETY NET

### Roof Catching Scaffolding

Art. Nr.	Item	Weight	Unit
272V1	Protection Post SB 2 m with Cross Tube galvanized	9,50	pc
272 11	Protection Post SB 2 m without Cross Tube	7,00	pc
272V11	Protection Post SB 2 m without Cross Tube galvanized	7,80	pc
112 0024	Bracket 1,2 m for Protection Scaffolding	10,00	pc
112V0024	Bracket 1,2 m for Protection Scaffolding galvanized	10,30	pc

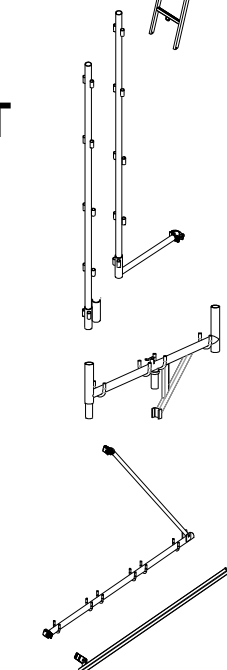

### Protection Fan for Scaffolding

Art. Nr.	Item	Weight	Unit
271V1	Protection Fan for Scaffolding galvanized	14,50	pc

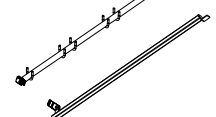

### Protection Grid for Roof Scaffolding

Art. Nr.	Item	Weight	Unit
270V1	Protection Grid 2,5 x 1 m galvanized	16,50	pc
270V2	Supporting Tube 1,5 m with Carabine galvanized for Protection Grid	2,90	pc
270V3	Adjustable Chain with Carbine 1,4 m galvanized for Protection Grid	0,70	pc

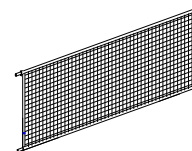

### Safety net

Art. Nr.	Item	Weight	Unit
600 04	Safety Net 2,50 m white 2,50 m x 100 lm = 250 m <sup>2</sup>	11,00	pc
600 02	Safety Net 2,50 m white Imprint: RINGER (red) 2,50 m x 100 lm = 250 m <sup>2</sup>	15,00	pc
600 1	Tarpaulin 2,70 m x 10 lm = 27 m <sup>2</sup> (200 g/m <sup>2</sup> )	7,50	pc
254 871	Protection Net 2 x 10 m (personal protection)	5,60	pc
PNETZ	Safety Net Inspection (required yearly)	0,00	pc
600 0004	Expendible Fixer for Net and Tarpaulin (100 pcs per package)	0,50	pc



## COUPLERS for Tubes Diameter 48,3 mm

### Screw Couplers

Art. Nr.	Item	Weight	Unit
113V0012	Swivel Coupler galvanized	1,50	pc
113V0013	Right Angle Coupler galvanized	1,40	pc
113V0014	Coupler for connecting tubes galvanized	1,70	pc
290 0099	Half Coupler black	0,70	pc
113V0017	Tube Connector ø 48 mm galvanized	1,10	pc
290 0044	Hammerheadscrew M14 for Coupler without nut	0,09	pc
290 0043	Nut SW22 for Coupler	0,04	pc

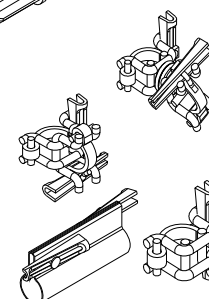
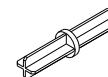
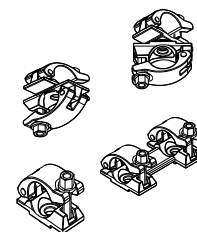

### Wedge Couplers

Art. Nr.	Item	Weight	Unit
115V0009	Swivel Wedge Coupler galvanized	1,60	pc
115V0010	Right Angle Wedge Coupler galvanized	1,50	pc
115V0008	Longitudinal Wedge Coupler for connection of tubes galvanized	1,20	pc
290 0041	Half Wedge Coupler for welding	0,80	pc

### Special Couplers and Scaffolding Ratchet

Art. Nr.	Item	Weight	Unit
290V40	Half Wedge Coupler with Pin ø 14x100 mm for Doppelgeländer galvanized	1,07	pc
113V171	Angle Connector for Braces galvanized	0,58	pc
290 0013	Tube Connector for Braces ø 27 - 32 mm galvanized	1,00	pc
290V42	Wedge Coupler with 2 loops for Guardrail	0,80	pc
81008	Coupler for mounting Toe Board galvanized	2,00	pc
290 10	Scaffolding Ratchet 19/22 solid with Belt Holder	0,50	pc

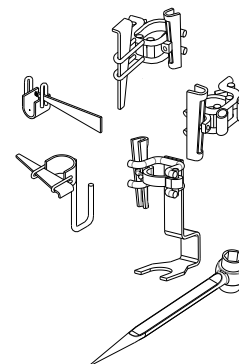

### Tubes galvanized

Art. Nr.	Item	Weight	Unit
115V0012	Tube 48/2,7 mm galvanized	3,80	LM



## RINGER

Over 75 years experience in construction!

### OUR LOCATIONS:

**Central office, warehouse and production - Regau**

4844 Regau, Römerweg 9 Austria  
Phone +43 (0) 7672/727 11-0, Fax +43 (0) 7672/788 05

**Warehouse - Vienna**

2522 Oberwaltersdorf, Am Satzfeld 5  
Phone +43 (0) 2253/214 87, Fax +43 (0) 2253/214 87-20

**Warehouse Lower Austria - Emmersdorf**

3644 Emmersdorf b. Melk, Donaustrasse 7  
Phone +43 (0) 2752/714 85, Fax +43 (0) 2752/714 85-20

**Warehouse Styria - Friesach (Gratkorn)**

8114 Friesach (Gemeinde Gratkorn), Dorfstrasse 1  
Phone +43 (0) 3127/415 50, Fax +43 (0) 3127/415 50-99

**Warehouse Carinthia - Klagenfurt**

9020 Klagenfurt, St. Jakoberstraße 38  
Phone +43 (0) 463/31 88 99, Fax +43 (0) 463/31 88 99 99

**Warehouse Tirol - Langkampfen**

6336 Langkampfen, Kirchbichlerstrasse 17  
Phone +43 (0) 5332/81 700, Fax +43 (0) 5332/81 700 20